OPERATION AND MAINTENANCE MANUAL MOBILE WELFARE



CONTENTS

1.	Introduction	5
1.2	General Safety	7
2.	Know Your Unit	8
2.1	Technical Diagrams and Guides	9
2.2	Masses and Dimensions – Canteen Space & Canteen Office Space	11
3.	Transporting The Cabin	12
3.1	Preparing the Unit for Towing – Electric Hydraulics	13
3.2A	Attaching the Unit to a Towing Vehicle – Pin & Eye Coupling	16
3.2B	Attaching the Unit to a Towing Vehicle – Ball Hitch Coupling	18
3.3A	Uncoupling the Unit – Pin & Eye Coupling	20
3.3B	Uncoupling the Unit – Ball Hitch Coupling	22
3.4	Deploying the Unit	23
3.5A	Anti-Vandal Cover – Cowl	25
3.5B	Anti-Vandal Cover – Flap	26
3.6	Using the Low Level Lifting Eyes	27
4.	Powering The Unit	29
4.1	Using an External Power Source	30
4.2	Using the Redbox Generator	31
4.3	Generator Checks Before Use	32
4.4A	Starting the Generator – Eco+, Eco Hybrid	34
4.5A	Turning the Power Off – Eco+, Eco Hybrid	35
5.	Electrical System & Equipment	36
5B	Using the Eco+ Electrical System	37
5B.1	Cabin Power Isolator Switch	38
5B.2	Internal/External Power Switch	38
5B.3	Power Selector Switch	39
5B.4	Using the Electrical Equipment – Eco+	39
5B.5	Using the Heaters	41
5B.6	Electrical Installations	43
5C	Using the Eco Hybrid Electrical System	45
5C.1	Cabin Power Isolator Switch	46
5C.2	Internal/External Power Switch	46
5C.3	Power Selector Switch	47
5C.4	Using the Electrical Equipment – Eco Hybrid	47
5C.5	Using the Heaters	50
5C.6	Electrical Installations	52

CONTENTS

6.	Inside Your Welfare Unit	54
6.1	Drinking Water	55
6.2	Hand wash water tank	55
6.3	Waste water tank	55
6.4	Soap dispenser	56
6.5	Paper towel dispenser	56
6.6	Drinking cup dispenser	56
6.7	Food Preparation	57
6.8	Carbon Monoxide Alarm	57
6.9	Bench Seating	57
6.10	Dedicated Storage	58
6.11	Windows And Shutters	58
6.12	Magnetic Door Stays	59
6.13	Door Locks	59
7.	Using Your Toilet	60
7A	Using Your Toilet – Chemical	61
7A.1	Toilet	61
7A.2	Hand Wash Basin	62
7A.3	Instant Hot Wash	62
7A.4	Dispensers	63
7A.5	Pir-Sensor Controlled 12V LED Lighting	63
7A.6	Heater	64
7A.7	Toilet Door Locks	64
7A.8	Reservoir Tanks	65
7B	Using Your Toilet – Fresh Water	66
7B.1	Toilet	66
7B.2	Hand Wash Basin	66
7B.3	Instant Hot Wash	67
7B.4	Dispensers	67
7B.5	Pir-Sensor Controlled 12V LED Lighting	67
7B.6	Toilet Door Locks	68
7B.7	Reservoir Tanks	68
8.	Maintenance	70
8.1	Changing A Wheel	71
8.2	Brake Setting Procedure – Preparation – Single And Twin Axle	74
8.2A	Brake Setting Procedure – Single Axle	75
8.2B	Brake Setting Procedure – Double Axle	77
8.3	Brake Check And Test	78
8.4	Service Checks	80
8.5	Electrical Checks	81
8.5.1A	Fuse Box Check – Eco+, Eco Hybrid	81

CONTENTS

9.	Diagnostics	82
9A	Diagnostics – Eco+, Eco Hybrid	83
9A.1	Generator Not Starting – No Lights On Control Panel	84
9A.2	Generator Not Starting – Control Panel Lights Working	86
9A.3	Generator Starts But Cuts Out	87
9A.4	Generator Runs But No 230V Power To Cabin	89
9A.5	No 12V Power In Cabin – Eco+ And Eco Hybrid Only	91
9A.6	Water Heater Not Working – Canteen	91
9A.7	Water Heater Not Working – Toilet	93
9A.8	Room Heater Not Working – Fan, Plinth	94
9A.9	Room Heater Not Working – Webasto 12V HVO/diesel heater	94
9A.10	Electric Hydraulic System Not Working – No Power To Rams When Remote Control Is Operated	95
9A.11	Generator Stops Running But Then Restarts – Redbox Infinity Generators Only	96
9A.12	Generator Starts Running With No User Intervention – Eco Hybrid Only	97
9A.13	Generator Stops Running After 50 Minutes Use	97
10.	Warranties	98
10.1	Manufacturer Standard Warranty – 12 Months	99
10.2	Generator Servicing & Warranty	100
11.	Towing Advice & Legal Obligations	101
11.1	Legal Obligations – Cabin & Towing Vehicle	102
11.2	Legal Obligations – Towing Vehicle Driver	105
11.3	Driving Advice	109
12.	Other Information	111
12.1	Safety Decals	112
13.	Legal Requirements – Mobile Welfare	114
13.1	Onsite Welfare Provision – Construction (Design And Management) Regulations 2015	115
13.2	Roadworthiness – Vca Type Approval Under Directive 2007/46/ec	116
13.3	Electric Installations – Bs7671 Iet Wiring Regulations 18th Edition	116

INTRODUCTION



1.1 INTRODUCTION

THANK YOU FOR USING THIS CALNAN MOBILE WELFARE UNIT.

To avoid personal injury or equipment damage, carefully read these instructions and ensure you understand them before using this equipment.

The information and instructions included in this manual are provided to help you get the best possible service from your welfare unit. To ensure that the unit is used safely and responsibly, we strongly recommend that this manual is read by all users prior to its operation, and that the recommendations are followed at all times. It is the responsibility of the operator to read and understand the contents of this manual before operating the vehicle for the first time.

If there is anything you do not understand, **DO NOT** use this equipment, and contact your supplier for advice. Ensure everyone responsible is fully conversant with the procedure for attaching the towing vehicle, towing, loading, setting up, removing, operating and maintaining the unit.

Certain information in this manual is governed by law and is subject to change without prior notice. Great care has been taken to ensure that the information is correct at the time of publication. However, it is the user's sole responsibility to ensure that they fully comply with all legal requirements. The unit manufacturer will not accept liability for any inaccuracy or incorrectly stated legal requirement.

Regular inspection, servicing and periodic maintenance will ensure many years of trouble free operation.

Calnan operate a policy of continuous improvement and reserve the right to change specifications without notice. The most current version of this manual will always be available online on our website or on request by telephone or email.

This Calnan range of mobile welfare cabins are road towable units suitable for up to 20 personnel.

Depending on model/specification, these self contained units may be equipped with a kitchen/restroom, one or more toilets, a dedicated drying room, a plant/drying room, an office, and/or sleeping quarters. This is their intended use.

Electrical supply can be taken either from mains hook up or from a built in generator.

The unique design means that raising and lowering the body requires little effort from the operator and takes under three minutes from disconnecting from the towing vehicle to being fully operational.

1.2 GENERAL SAFETY

SAFETY IS EVERYONE'S RESPONSIBILITY

Before using this equipment and to avoid personal injury, carefully read and understand these instructions. If there is anything you do not understand, DO NOT use this equipment, contact the supplier for advice.

Make sure you are aware of all the safety requirements and that this equipment is suitable for the location. When manoeuvring the unit into position, if working on a public road or in a public accessible space use the high intensity warning beacons fitted to the towing vehicle or its hazard warning lamps to raise awareness of its movement. If visibility is limited use a banksman or other assistance to guide you.

When raising or lowering the unit, the area must be cordoned off to create a safe zone, isolating the unit from the general public and bystanders.

This equipment must not be moved, set up, used or dismantled by persons who are under the influence of alcohol or drugs. Do not use this equipment if you are tired or unwell. The equipment must not be operated, moved or used by any person not deemed competent to do so. You **MUST** perform a risk assessment before siting this equipment to ensure your safety and the safety of others. Wear suitable personal protective equipment whenever making adjustments to the unit.

Do not wear loose jewellery or clothing that may get in the way or become trapped in the mechanism. Carefully inspect the unit before towing or before use.

If there is any doubt about its condition, **DO NOT CONTINUE.**

This equipment may only be used on smooth level ground, which is able to bear its weight and its load.

RISK ASSESSMENT

It is the user's responsibility to carry out a full risk assessment before siting the unit, to establish a safe zone including (but not limited to):

GROUND HAZARDS

Ensure suitable smooth level ground capable of bearing the mass of the unit plus occupants etc in all weather conditions and check proximity to underground services. If permission is required, obtain it before use.

SIDE HAZARDS

Proximity to other buildings trenches and equipment, clearances for exhaust outlet and ventilation and light where required.

OVERHEAD HAZARDS

Proximity to power supply and communication cables, lighting systems, drainage systems and other services.

PREPARATION FOR TOWING

Before towing the unit, you must ensure that the fresh water, waste water and drinking water containers are emptied. Switch the generator off. Empty the toilet and wash hand basin reservoirs. Pack away all utensils, cups, plates etc. and remove any equipment that was not supplied with the unit. Lock all doors, windows and protective shutters. The unit must not be used as a payload trailer; additional items carried in the trailer may cause the unit to be overweight.

WORK AREA PREPARATION

Survey the ground area where the unit is to be used, clear it of obstructions, anything that may puncture the tyres and similar items. Once the unit is in the work area, use barriers, signs and tape to create a safe zone. Keep bystanders and unauthorised persons away when setting the unit up.

KNOW YOUR UNIT







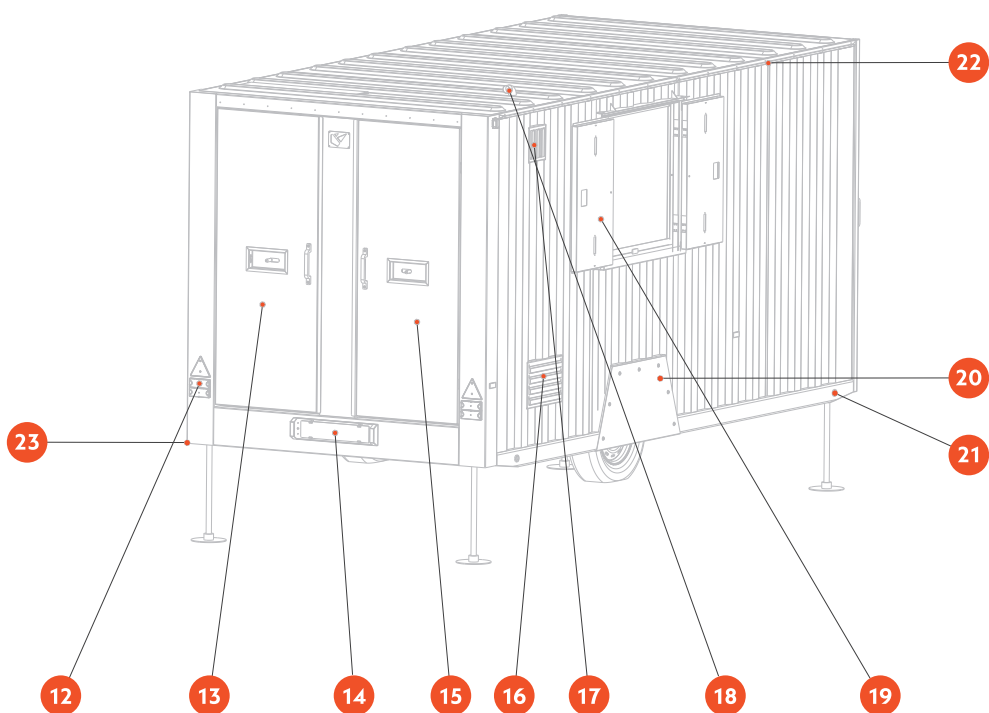
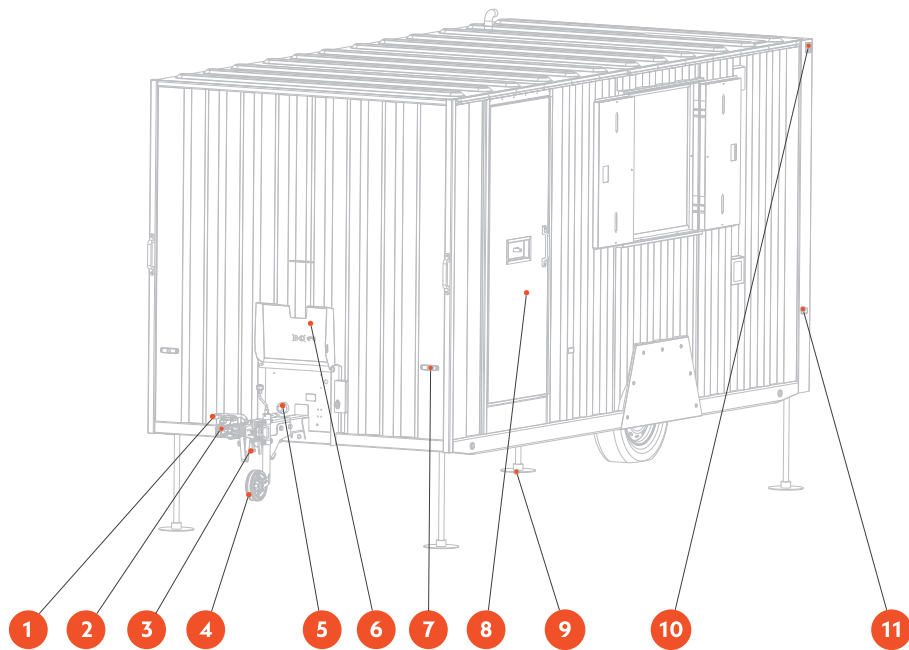

2

2.1 TECHNICAL DIAGRAMS AND GUIDES

Here we give a guide to the most important external elements of your Calnan mobile welfare unit. See next page for descriptions.



2.1 TECHNICAL DIAGRAMS AND GUIDES

Item No.	Description
1	Parking brake
2	Either pin & eye or 50mm standard ball coupler with inertia overrun brake actuator (HPP handbrake protection plate)
3	Break away activation cable* 
4	Jockey wheel
5	Road lighting connection socket
6	Protective anti vandal cover – either flap or cowl
7	Front side marker lamps / reflectors * 
8	Cabin entrance door (position is model dependent, differs in twin toilet models)
9	Hydraulic lift cylinders (rams) – 4 ram version shown, in 2 ram models the rams are positioned just in front of wheels
10	End outline marker lamps * 
11	Side marker reflectors / lights * 
12	Combination stop / tail / direction indicator lamps * 
13	Toilet access door (position is model dependent, differs in twin toilet models)
14	Number plate position * 
15	Generator / drying room access door
16	Generator cooling air inlet
17	Generator cooling air outlet
18	Generator exhaust
19	Window / security shutter
20	Detachable wheel arch
21	Low-level lifting points
22	Triangulated stainless steel chain guard
23	Stainless steel anti-wear strips



NOTE

It is an offence to tow the vehicle if these items are not fitted and working.

Cabin Size	Axle Capacity (Kg)	Tyre Size	Load Rating	Tyre Pressure (psi)	Rim Size
12ft	1800	155/70 R12	104	90	4.5J x 12
	1900	185/70 R13	106	87	6.0 x 13
	2000	185/70 R13	108	87	6.0 x 13
14/16/18ft	2300	205/75 R16	112	76	5.5J x 16
	2500	215/75 R16	113	70	5.5J x 16
24ft	2000	205 R14	108	65	5.5J x 14
	1800	185/70 R13	108	87	6.0 x 13

2.2 MASSES AND DIMENSIONS

CANTEEN SPACE & CANTEEN OFFICE SPACE

Here's a guide to the masses and dimensions of our mobile welfare Canteen Space and Canteen Office cabins.

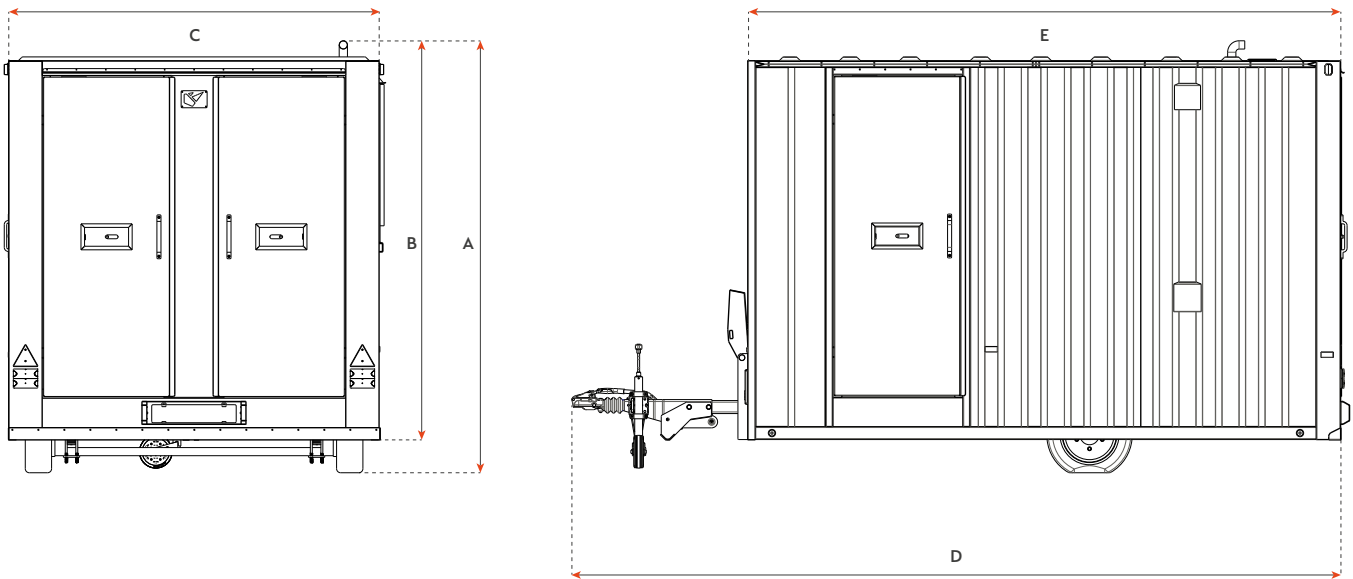

Model	Dimensions (mm)					Max Mass (kg)
	A	B	C	D	E	
12ft	2660	2460	2350	4790	3650	2100
14ft	2760	2460	2350	5340	4200	2650
16ft	2760	2460	2350	5950	4810	2650
18ft	2756	2500	2350	6600	5460	2650
24ft	2756	2500	2350	8340	6800	3500

Capacities (litres)							
Canteen Water Storage			Fresh Water Toilet		Chemical Toilet		Fuel Tank
Drinking	Clean	Waste	Clean	Waste	Clean	Waste	
20	25	25	140 (Twin 280)	150 (Twin 300)	65 (Twin 130)	225 (Twin 450)	58

TRANSPORTING THE CABIN



3

3.1 PREPARING THE UNIT FOR TOWING ELECTRIC HYDRAULICS



IMPORTANT

Before towing, the following steps must be followed:

- The fresh water, waste water and drinking water containers in the canteen should be emptied.
- In the toilet, the hand wash basin reservoirs and the toilet itself should also be emptied.
- Switch the generator OFF.
- Remove any unauthorised payload, such as tools, equipment, clothes and canteen equipment.
- Lock the windows and close security shutters.

- Lock all doors and ensure all umbilical connections are safely disconnected.
- The GVW of the towing vehicle must be no more than 18,000 kg

CAUTION: The welfare unit is not designed as a payload trailer. Any additional items or material carried in the trailer may exceed its maximum mass. It is the driver's responsibility to ensure this is not the case.

NOTE: The images shown in this manual are of a 2-ram electric hydraulic unit but the procedure is the same for a cabin with 4-rams.

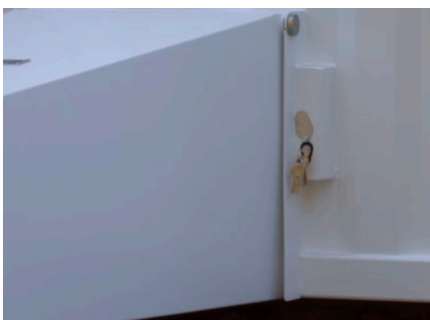

1. First unlock the anti-vandal cover using the key. Remove the key and close the lock seal to prevent water or dirt entry while towing.



2. Raise the anti-vandal cover into the towing position.



3. Then engage the anti-loose fastener and the safety pin to ensure the cover stays in the towing position when on the road.



4. Raise the parking brake lever to engage the brake.



5. Turn on the Cabin Power Isolator switch inside the cabin.



6. Remove the remote control from its storage position inside the bench behind the generator and connect the remote control's 7 pin plug to the correct socket on the front of the unit.



7. Press the black RAISE button on the remote control to extend the ram cylinders to raise the cabin until the wheels are clear of the ground.



8. Pull the handle and rotate the jockey wheel assembly into the down position.



9A. Single Axle Unit

Lift the spring bolt into the open position, then push in handle to engage the axle locking mechanism. Then release the spring bolt making sure it covers the washer, to stop the axle locking rod from moving forward.



9B. Double Axle Unit

Carry out the same procedure as for a single axle units using the two axle bolts found on the side of the unit. Lift the spring bolt into the open position, then push in handle to engage the axle locking mechanism. Then release the spring bolt making sure it covers the washer, to stop the axle locking rod from moving forward. Repeat for both axles.

 **NOTE**

If your cabin has a double axle (all 24ft cabins are double axle), the axle locking mechanism handles are situated on the side of the unit near the wheel arches.



10. Stand clear of the drawbar and jockey wheel assembly as the unit is lowered to the ground.



11. Ensure there are no obstructions beneath the unit, then press the white LOWER button on the remote control to retract the rams and lower the unit onto the road wheels and jockey wheel.



12. Continue to press the LOWER button until the ram cylinders have fully retracted.

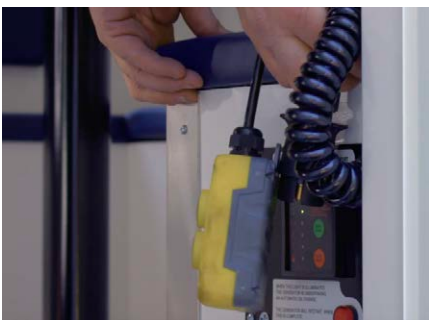

13. Unplug the remote control unit and stow it safely inside the bench in the cabin for road use.



14. Turn the Cabin Power Isolator switch in the cabin to the OFF position.

 **You are now ready to couple your unit to the towing vehicle.**

3.2A ATTACHING THE UNIT TO A TOWING VEHICLE PIN & EYE COUPLING



1. To attach your cabin to a towing vehicle it should be in a raised position with wheels on the floor and ramps raised. See Manual Section 3.1 for instructions.



2. With the unit positioned on level ground apply the parking brake by raising the lever.



3. Manoeuvre the towing vehicle so the coupling eye is aligned.

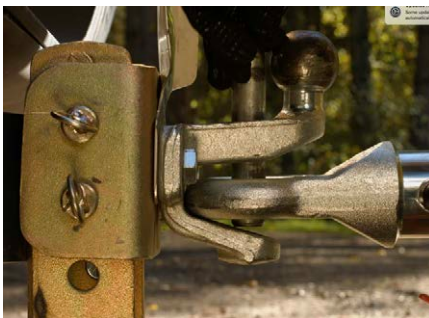

4. Insert coupling pin.



5. Secure with the safety clip.



6. Attach the breakaway cable to tow hitch of the towing vehicle and ensure it is safe and operational.



7. Connect the lighting cable plug to the socket of the towing vehicle and ensure all lights are functioning correctly.



8. Turn the jockey wheel operating handle clockwise to raise the jockey wheel clear of the ground.



9. Pull the jockey wheel handle to release.



10. Rotate the jockey wheel assembly through 90 degrees clockwise into locked position.



11. Release the unit's parking brake before towing by lowering the lever.

✔ **Your unit is now attached and ready to be towed.**

3.2B ATTACHING THE UNIT TO A TOWING VEHICLE

BALL HITCH COUPLING



1. To attach your cabin to a towing vehicle it should be in a raised position with wheels on the floor and ramps raised. See Manual Section 3.1 for instructions.



2. With the unit positioned on level ground apply the parking brake by raising the lever.

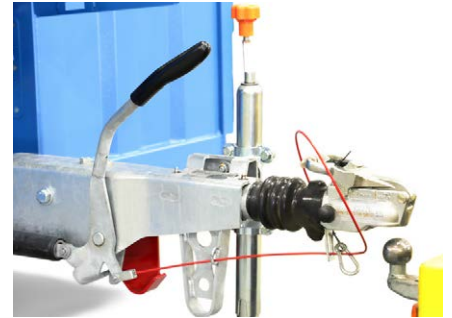

3. Turn the Jockey wheel operating handle anti-clockwise to raise the coupling head higher than the towing vehicle's tow ball. Then manoeuvre the towing vehicle so the ball is beneath the ball coupler.



4. Raise and hold the coupling head handle in the up position, and then turn the jockey wheel clockwise to lower the coupling onto the tow ball.

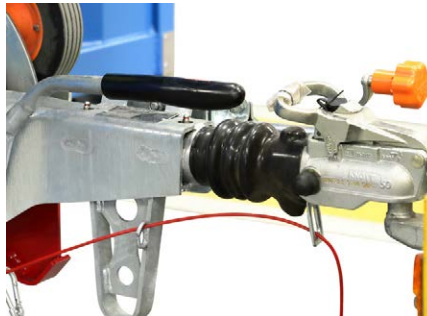

5. When almost fully lowered let go of the coupling head handle and allow it to snap closed over the tow ball. Check that the coupling head is fully engaged on the tow ball.

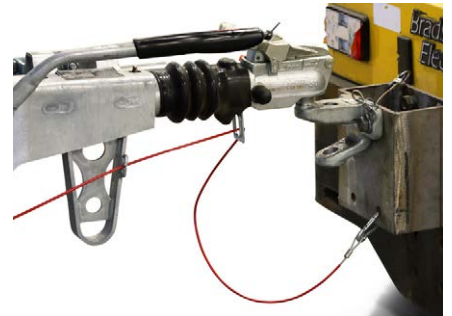

6. Attach the breakaway cable to tow hitch of the towing vehicle and ensure it is safe and operational.



7. Connect the lighting cable plug to the socket of the towing vehicle and ensure all lights are functioning correctly.



8. Turn the jockey wheel operating handle clockwise to raise the jockey wheel clear of the ground.



9. Pull the jockey wheel handle to release.



10. Rotate the jockey wheel assembly through 90 degrees clockwise into locked position.



11. Release the unit's parking brake before towing by lowering the lever.

✔ **Your unit is now attached and ready to be towed.**

3.3A UNCOUPLING THE UNIT

PIN & EYE COUPLING



1. Make sure your cabin is situated on firm level ground able to support the weight of the unit. Inspect the ground underneath the unit and check there are no items which may damage the underside of the unit.



2. To uncouple the unit from the towing vehicle, first apply the parking brake.



3. Pull the jockey wheel handle to release.

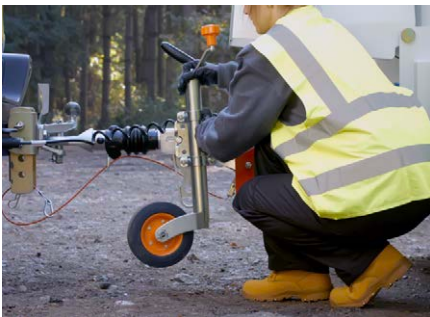

4. Rotate the jockey wheel assembly through 90 degrees anti-clockwise into down position.



5. Then turn the jockey wheel operating handle anti-clockwise to lower the jockey wheel to the ground.



6. Disconnect the lighting cable plug from the socket on the towing vehicle.



7. Detach the breakaway cable from the tow hitch of the towing vehicle.



Safety Pin

8. Next remove the safety clip from the pin and eye hitch.



9. Remove the coupling pin.

✔ **Your unit is now detached from the towing vehicle and ready to use.**

3.3B UNCOUPLING THE UNIT

BALL HITCH COUPLING



1. Make sure your cabin is situated on firm level ground able to support the weight of the unit. Inspect the ground underneath the unit and check there are no items which may damage the underside of the unit.



2. To uncouple the unit from the towing vehicle, first apply the parking brake.



3. Pull the jockey wheel handle to release.



4. Rotate the jockey wheel assembly through 90 degrees anti-clockwise into down position.



5. Then turn the jockey wheel operating handle anti-clockwise to lower the jockey wheel to the ground.



6. Disconnect the lighting cable plug from the socket on the towing vehicle.

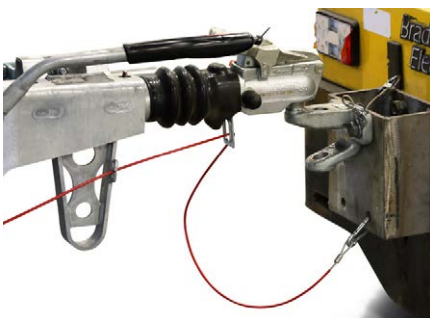

7. Detach the breakaway cable from the tow hitch of the towing vehicle.

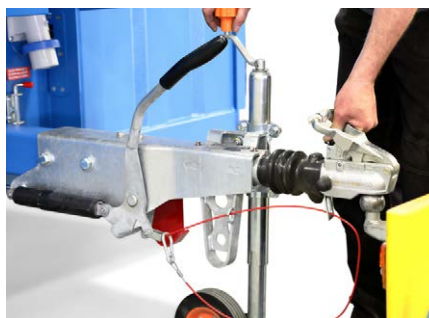

8. Lift the handle behind the tow hitch to release the ball hitch from the towing ball. At the same time turn the jockey wheel handle anti-clockwise.

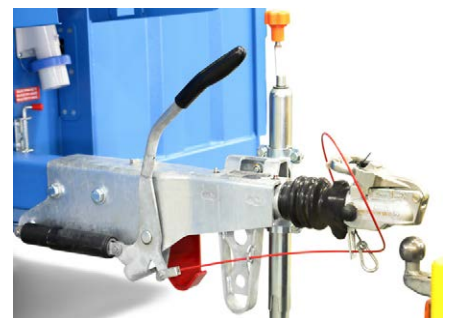

9. Keep turning until the hitch is raised above the ball and the towing vehicle can be removed easily.

✔ Your unit is now detached from the towing vehicle and ready to use.

3.4 DEPLOYING THE UNIT



CAUTION

During use, the unit **MUST** be uncoupled from the towing vehicle.



1. Make sure your cabin is situated on firm level ground able to support the weight of the unit. Inspect the ground underneath the unit and check there are no items which may damage the underside of the unit.



2. Uncouple your vehicle from the towing vehicle as described in manual section 3.3 making sure the cabin parking brake is on. Move the towing vehicle away and park at a safe distance.



3. Turn on the Cabin Power Isolator switch inside the cabin.

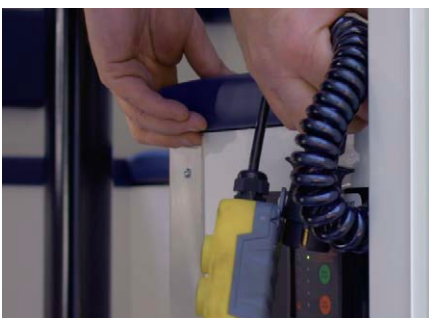

4. Remove the remote control from its storage position inside the bench behind the generator and connect the remote control's 7 pin plug to the correct socket on the front of the unit.

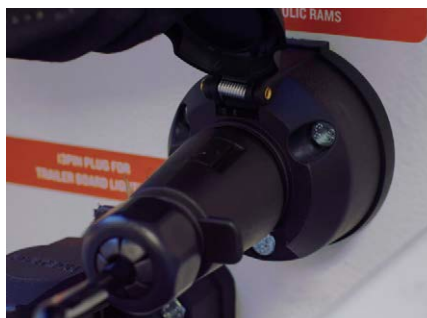



5. Press the black RAISE button on the remote control to extend the ram cylinders to raise the cabin until the wheels are clear of the ground.



6A. (Single Axle Version) Locate the axle rod handle under the anti-vandal cover on the front of the unit. Lift the spring bolt into the open position, then pull out the handle to release the axle locking mechanism.



6B. (Double Axle Version) Locate the two axle handles on the side of the cabin. Lift the spring bolt into the open position, then pull out the handle to release the axle locking mechanism. Repeat for both axles.



7. Stand clear of the drawbar and jockey wheel assembly as the unit is lowered to the ground.



8. Ensure there are no obstructions beneath the unit, then press the white LOWER button on the remote control.



9. Continue to press the LOWER button until the ram cylinders have fully retracted and the unit is lowered to the ground.



10. Release the unit's parking brake by lowering the lever.

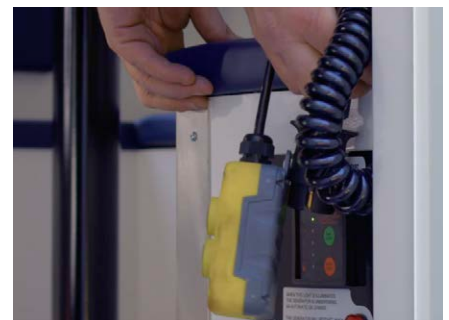

11. Unplug the remote control unit and stow it safely inside the bench in the cabin for road use.



12. Turn the Cabin Power Isolator switch in the cabin to the OFF position.

✔ **You are now ready to lower your anti-vandal cover.**

3.5A ANTI-VANDAL COVER COWL

Your Calnan welfare unit is protected from theft by an anti-vandal cover with an anti-prise bear-claw lock, available in two styles – flap and cowl. Here we show you how to lower your anti-vandal cover into deployed position. To raise it into towing position, just reverse the procedure.



1. Release the anti-loose fastener and safety pin.

3 - Transporting The Cabin



2. Gently lower the cowl to the ground covering the tow hitch.



3. Once in position, lock the cover. Remove the keys and close the lock seal to protect against dirt or damage.

3.5B ANTI-VANDAL COVER FLAP



1. Release the anti-loose fastener and safety pin.



2. Gently lower the flap covering the electric panel.



3. Once in position, lock the cover. Remove the keys and close the lock seal to protect against dirt or damage.

3.6 USING THE LOW LEVEL LIFTING EYES



IMPORTANT

Before transporting your unit, the following steps must be followed:

- The fresh water, waste water and drinking water containers in the canteen should be emptied.
- In the toilet, the hand wash basin reservoirs and the toilet itself should also be emptied.
- Switch the generator OFF.
- Remove any unauthorised payload, such as tools, equipment, clothes and canteen equipment.
- Lock the windows and close security shutters.
- Lock all doors and ensure all umbilical connections are safely disconnected.



CAUTION

The welfare unit is not designed as a payload trailer. Any additional items or material carried in the trailer may exceed its maximum mass. It is the driver's responsibility to ensure this is not the case.

As well as being towed, your mobile welfare unit can also be lifted with a crane and moved around site or lifted onto a lorry for transport. To facilitate this, the unit is equipped with lifting eye holes.

The eye holes are set at a low level which means avoidance of Health & Safety "Working at Height" issues associated with attaching cables to roof-mounted eyes.

Our removable eye system means security is improved as the eyes are not fixed to the units reducing the risk of theft by crane.

CAUTION

During any lift of a unit, use **ONLY** the proprietary lifting eyes supplied with the unit.

One eye must be used on each corner of the unit. This promotes a level lift.

To ensure safe use of the lifting eyes, they must be fitted correctly.



1. First remove the plugging bolt from the eye hole.

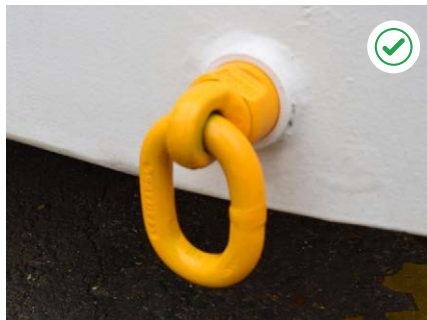

2. Then screw in the lifting eye, ensuring there is a face to face contact between the side of the cabin and the face of the lifting eye.



3. Do this for all four lifting eyes. You are now ready to attach lifting straps or chains.



4. When lifting, the cabins will be protected from chain or strap damage by the stainless steel chain guard protection rail along the top of the unit.



5. When lifting is finished please, remove the eyes, replace the plugs and store the lifting eyes in the unit.

POWERING THE UNIT



Once your welfare cabin is safely deployed, you need to get it up and running. Electricity can be supplied from either an external source or from the unit's on-board Redbox generator.

With the ECO+ electrical specification, several items can be run from battery power alone without the need for generator or external power. These items are: 12V LED lighting; 12V charging points for mobiles, tablets, notebooks and 12V diesel/HVO heater (if specified).

If you have Eco Hybrid electrical specification, the following additional items can also be run from battery alone: low power inverted 230V power sockets to run computers, printers etc.; 12V diesel/HVO heater.

4

4.1 USING AN EXTERNAL POWER SOURCE



1. The welfare unit can be connected to an external electrical power supply using a standard 32A 230V AC cable connected to the socket located under the anti-vandal cover.



2. Once connected, locate the Internal/ External Power Selector Switch close to the floor under the worktop. Turn the switch to position 1 for external power.

4.2 USING THE REDBOX GENERATOR

Your welfare cabin is fitted with either a Redbox standard generator or a Redbox Infinity generator. If it is an Infinity, that will be stated on the side panel of the generator.

This on-board generator is used to power the hot water, plinth and fan heating if fitted, appliances, 230 volt 3-pin power points and charge the battery.

The generator is usually located in a self contained compartment at the rear of the unit which can also be used for drying wet clothing etc.

On the generator itself, there is an emergency stop control, the large red button located on the panel to the left of the generator. Push this button in to stop the generator in an emergency. Turn the button to the right to release when resetting the control.

IMPORTANT

The patented design of the Redbox INFINITY generator means that every 50 hours of operation, the generator will stop to perform an automatic oil change cycle which takes 5 minutes. While the oil change is happening a red light will illuminate on the generator control panel in the canteen.



During the oil change cycle, a valve is automatically opened allowing the oil from the engine sump to drain to the external oil tank. The oil from the engine merges with the oil inside the external tank then the oil is pumped back into the engine sump passing through the oil filter and delivering clean oil back into the engine. After 5 minutes and when the oil in the engine sump is at the correct level the valve is closed and the pump stops. The generator is now available for use and will restart automatically.

On top of the generator is the main generator control panel. This contains:

1. An RCD panel
2. The blue generator alarm reset button
3. Circuit breakers for the 12V DC 2A and 20A systems and for the 220V AC 1 A system
4. The DSE generator control device



NOTE

Do not use the buttons on the generator to switch the generator on and off unless in an emergency. See Section 4.4 for how to start your generator correctly.

Service Intervals	
Redbox	1000 hours
Redbox Infinity	2000 hours

4.3 GENERATOR CHECKS BEFORE USE

Before switching your generator on, it is important to always check your oil and fuel levels and top up as necessary. There are two different ways to check and fill your oil depending on if you have a Redbox standard generator or a Redbox Infinity generator. It is essential you follow the correct instructions.



RedBox Standard



RedBox Infinity

4.3.1A OIL CHECK REDBOX INFINITY GENERATOR



1. First remove the generator side cover.



2. Check the oil using the two circular gauges found towards the base of the generator on the sump tank. The oil should be filled to the Maximum line marker next to the top gauge.

CAUTION

To check the oil levels on the Redbox Infinity generator, it is very important to use the gauges found on the external oil sump reservoir. Do not use the dipstick in the generator engine to check oil levels. Never fill the oil reservoir through the dipstick hole or you risk overfilling the engine itself.



3. If your generator needs more oil, please remove the cap on top of the external sump oil reservoir that has the gauges on the front. Fill with suitable engine oil until the level reaches the maximum mark halfway up the top sight glass. Do NOT overfill. Always use the grade of oil specified in the appropriate RedBox generator manual.

4.3.1B OIL CHECK REDBOX STANDARD GENERATOR



1. First remove the generator side cover.



2. To check the oil in a standard Redbox generator, remove the dipstick with the orange cap located in the side of the engine. Check that the oil level is between the MIN and MAX markers on the dipstick.



3. If your generator needs more oil, fill with suitable engine oil through the same hole as the dipstick is located. Be careful not to overfill, only fill up to the MAX level on the dipstick. Always use the grade of oil specified in the appropriate RedBox generator manual.

4.3.2 FUEL CHECK



1. The fuel gauge and fuel tank cap for the RedBox generator are both set into the floor of the generator room in front of the generator.



2. Please check the fuel level using the gauge.

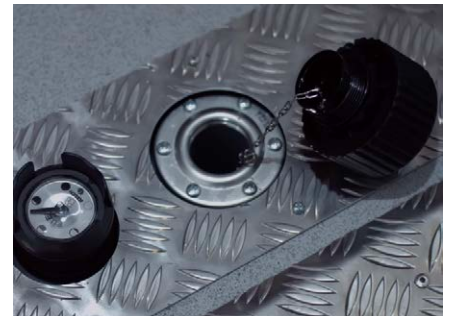

3. If fuel is needed, remove the fuel tank cap and fill the fuel reservoir with the correct amount of diesel or HVO biofuel. Replace the cap.

4.4A STARTING THE GENERATOR STANDARD, ECO+, ECO HYBRID

The generator is controlled directly from the remote control panel located in the canteen area.



1. Before starting the generator, turn the Cabin Power Isolator switch in the cabin to the ON position.



2. To start the generator, press the green button on the front of the cabin control panel once.



3. When the generator is running, set the Internal/External Power Switch to Position 2 for Internal (generator) power.

4.5A TURNING THE POWER OFF ECO+, ECO HYBRID



1. When you want to stop the generator, press the red button on the cabin control panel once.



2. When you leave the cabin for an extended period during or at the end of the day, or before towing, please ensure the Cabin Power Isolator switch is switched off to avoid accidental discharge of the battery and protect against theft.

CAUTION

Except in an emergency, the STOP button on the generator itself should never be used for shutting it down. Doing this risks the full discharge of the batteries and could prevent the generator being restarted.

ELECTRICAL SYSTEM & EQUIPMENT



Calnan standard welfare units are fitted with one of the following two electrical systems – Eco+ or Eco Hybrid. Please go to one of the following sections depending on your system:

- 5B Eco+
- 5C Eco Hybrid

5

5B USING THE ECO+ ELECTRICAL SYSTEM

Your cabin is fitted with our ECO+ electrical system. Please note that this system allows you to use the ram hydraulics, 12V LED lighting and 12V USB charging sockets directly from the battery without the need for the generator to be on or an external power source to be connected.

If you want to use 230V power sockets, appliances, water heaters, plinth heater or fan heaters, you will need to switch the generator on or connect the external power source. See Manual Section 4 for instructions on how to do either of these.



All units have Certified Gold Standard electrics which means that all our cabin installations meet or surpass all current UK and EU legislation requirements.

5B.1 CABIN POWER ISOLATOR SWITCH



Before using any electrical items, switch the Cabin Power Isolator switch in the main cabin to the ON position. The Cabin Power Isolator isolates the battery from the cabin to prevent battery discharge when not in use. When this switch is off, it also means the hydraulic rams cannot be operated, helping to prevent theft and vandalism.



When the cabin is to be left unused for a period of time, and at the end of each day, turn the Cabin Power Isolator switch to the OFF position before leaving the cabin.

NOTE

The battery on an ECO+ unit is protected by a load shedder so it cannot deep discharge. This means a 50% charge is always kept available to be able to start the generator and power the electric hydraulic system.

If the 12V electrical items (lights and USB chargers) stop working without warning, it may be due to the load shedder function. If this occurs, turn the generator on and leave running for a while to charge the battery.

5B.2 INTERNAL/EXTERNAL POWER SWITCH



When the Cabin Power Isolator switch is on, make sure that the Internal/External Power switch is set correctly either to 1 for external power or 2 for internal generator power.

5B.3 POWER SELECTOR SWITCH



Located below the distribution board in the canteen area of the welfare unit, this switch is used to control the power supply to the 230V DC electrical outputs. It needs to be put in the correct position required according to the electrical appliances you wish to use.

Position 1 to power 230V sockets and appliances – the kettle and microwave.

Position 2 to operate the hot-water hand wash units.

Please note that when Position 2 is selected on the Power Selector switch, there will be no power to the sockets and appliances and in reverse, when position 1 is selected, there will be no power to the hot-water hand wash heaters.



NOTE

The plinth and fan heaters can be used with the Power Selector Switch in any position – 1, 2 or 0.

5B.4 USING THE ELECTRICAL EQUIPMENT ECO+

Your welfare cabin with ECO+ specified electrical system is equipped with various items of electrical equipment. Here we explain how to use each one in conjunction with the ECO+ system.

5B.4.1 12V LED LIGHTING



The cabin is fitted as standard with 12V LED ceiling lights which run off battery power only and do not require generator or external power. The Cabin Power Isolator switch must be in the ON position for all LED lights to function.

The lights within your canteen (and office/drying room if applicable) are operated via a switch on the wall.

The 12V LED ceiling lights in the toilet(s) and generator/drying room are operated via PIR sensor so there is no need to switch on, they will come on automatically as someone enters the room.

5B.4.2 USB CHARGING POINTS



12V USB charging points are provided to enable mobile phones, tablets and notebooks to be charged from the battery. Switch the Cabin Power Isolator switch to the ON position to use.

5B.4.3 230V POWER SOCKETS



The unit is equipped with a number of 230V power sockets. To use these, you need generator or external power. The Cabin Power Isolator switch must be ON and the Power Selector Switch must be in Position 1.

5B.4.4 KITCHEN APPLIANCES



The unit's food preparation area is supplied as standard with a kettle to make hot drinks and a microwave for hot food preparation. To use these, you need generator or external power. The Cabin Power Isolator switch must be ON and the Power Selector Switch in Position 1. If either of them does not appear to be working, make sure their dedicated power switch is in the on position.



5B.4.5 INSTANT HOT WATER HAND WASH UNIT



The hand washer heater draws water from a fresh water container located beneath the sink. Always ensure that there is sufficient water in the fresh water container.



CAUTION

Do not let the hand wash unit be run dry as this will result in damage to the unit.



To operate the instant hot water hand wash unit in an ECO+ unit, you need generator or external power. The Cabin Power Isolator switch must be ON and the Power Selector Switch must be in Position 2.

Make sure the water heater on/off switch is switched on. This is located under the sink.



To start the unit, simply turn the dial to the required temperature. The water is heated instantly and starts to flow. The temperature of the water can be controlled by turning the dial from 1 – Cool to 10 – Hot.



CAUTION

To avoid scalding set the water temperature to cool at start of use and gradually increase as required. Allow the water to run for a few seconds before use.

5B.5 USING THE HEATERS

Your ECO+ welfare cabin will be fitted with one or more of the following types of heater. Please follow these instructions on how to operate.

5B.5.1 PLINTH HEATER



Using the plinth heater requires generator or external power. The Battery Isolator switch must be ON. The Power Selector Switch can be in any position – 0, 1 or 2.



CAUTION

Use of the heaters with other electrical equipment may overload the generator capacity.

The switches to operate the plinth heater are situated on the front of the unit. The top switch turns the heater on and off. The lower switches control the temperature. Press the left hand switch for Low heat and the right hand switch for High.

If required, the master switch for the plinth heater is located beneath the bench seat cushion.

5B.5.2 FAN HEATER



Using the fan heaters requires generator or external power. The Cabin Power Isolator switch must be ON. The Power Selector Switch can be in any position – 0, 1 or 2. Make sure the Fan Heater wall switch is on. Pull the string handle to switch on or off. The fan heater is not thermostatically controlled.

The fan heater is protected by its own MCB in the distribution board.

5B.5.3 12V WEBASTO DIESEL/HVO HEATER

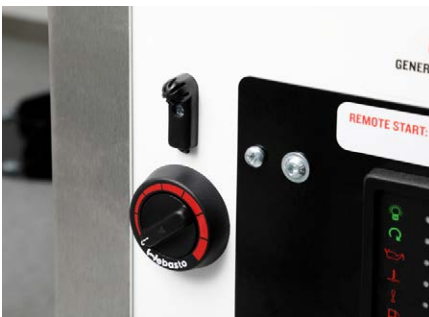

The 12V Webasto diesel/HVO heater can be purchased as an optional extra for ECO+ specified units. The Webasto does not need generator or external power to operate. The Cabin Power Isolator switch must be ON.

The Webasto heater uses a temperature sensor to monitor the temperature within the welfare unit. The temperature can be controlled by adjusting the dial. Turn to the right to switch on and increase temperature and left to decrease temperature and switch off.



The actual Webasto heater unit is located beneath the bench seating.

NOTE

When the Webasto is operating correctly, there should be a solid green light in the centre of the control dial. If this light is flashing, it means there is a fault. Please refer to the Webasto Operation Manual if this occurs.

5B.6 ELECTRICAL INSTALLATIONS

5B.6.1 FUSE BOX (230V DC DISTRIBUTION)



With the ECO+ system, the distribution board is usually located in the canteen area of the welfare unit. It will contain a RCD Main switch and Test button, and individual MCBs to protect the electrical circuits for the vehicle.



To test the Main RCD open the cover and ensure the RCD paddle is in the “ON” position. Press the TEST button, the paddle will move to the down “OFF” position and power will be cut to all circuits. If this does not happen the RCD is faulty and the electrical system should not be used until rectified by qualified personnel. To reset the RCD or any MCB push the paddles to the “ON” position.

5B.6.2 BATTERY



Your ECO+ specified cabin is fitted with a 145Ah battery which is located beneath the bench seating in the canteen area.

5B.6.3 BATTERY CHARGER



The AGM battery charger is located beneath the bench seating in the canteen area. The battery charger is fitted with an ON/ OFF switch. This should be in the ON position at all times. A red light illuminated on the charger indicates it is charging the batteries, a green light indicates that the charge is complete. The battery charger is automatically operated.

5B.6.4 BATTERY CHARGER ISOLATOR



The Battery Charger Isolator switch is located beneath the bench seating. Press the button to turn off the power supply to the battery charger if required.

5B.6.5 LOAD SHEDDER

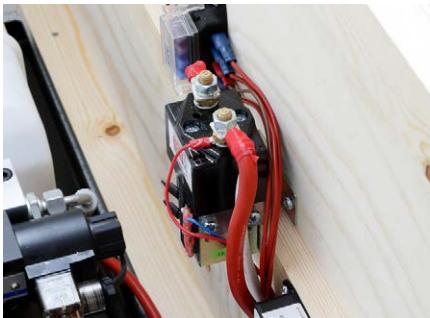

The load shedder is located beneath the bench seating in the rest room area. The load shedder protects the charge in the battery and isolates all 12V electrics when the battery voltage falls below a predetermined value. This ensures there is always sufficient power to start the generator and operate the electric hydraulic rams.

5C USING THE ECO HYBRID ELECTRICAL SYSTEM

Your cabin is fitted with our ECO HYBRID electrical system. Please note that this system allows you to use the ram hydraulics, 12V LED lighting, low power inverted 230V sockets (red fronts), 12V diesel/HVO heater and 12V USB charging sockets directly from the battery without the need for the generator to be on or an external power source to be connected.

If you want to use other 230V power sockets, appliances, water heaters, plinth or fan heaters, you will need to switch the generator on or connect the external power source. See Manual Section 4 for instructions on how to do either of these.



All units have Certified Gold Standard electrics which means that all our cabin installations meet or surpass all current UK and EU legislation requirements.

5C.1 CABIN POWER ISOLATOR SWITCH



Before using any electrical items, switch the Cabin Power Isolator switch in the main cabin to the ON position. The Cabin Power isolator isolates the battery from the cabin to prevent battery discharge when not in use. When this switch is off, it also means the hydraulic rams cannot be operated, helping to prevent theft and vandalism.



When the cabin is to be left unused for a period of time, and at the end of each day, turn the Cabin Power Isolator switch to the OFF position before leaving the cabin.

NOTE

Our ECO HYBRID units are fitted with a Smartgauge which automatically turns on the generator when the battery is low and then automatically shuts off when the charge cycle is complete, making sure there is always enough charge for the unit to function. If the Smartgauge fails for any reason, the battery is also protected by a load shedder so it cannot deep discharge. This means a 50% charge is always kept available to be able to start the generator and power the electric hydraulic system.

5C.2 INTERNAL/EXTERNAL POWER SWITCH



When the Cabin Power Isolator switch is on, make sure that the Internal/External Power switch is set correctly either to 1 for external power or 2 for internal generator power.

5C.3 POWER SELECTOR SWITCH



Located below the distribution board in the canteen area of the welfare unit, this switch is used to control the power supply to the 230V DC electrical outputs. It needs to be put in the correct position required according to the electrical appliances you wish to use.

Position 1 to power 230V sockets and appliances – the kettle and microwave.

Position 2 to operate the hot-water hand wash units.

Please note that when Position 2 is selected on the Power Selector switch, there will be no power to the sockets and appliances and in reverse, when position 1 is selected, there will be no power to the hot-water hand wash heaters.



NOTE

The plinth and fan heaters can be used with the Power Selector Switch in any position – 1, 2 or 0.

5C.4 USING THE ELECTRICAL EQUIPMENT ECO HYBRID

Your welfare cabin with ECO HYBRID specified electrical system is equipped with various items of electrical equipment. Here we explain to use each one in conjunction with the ECO HYBRID system.

5C.4.1 12V LED LIGHTING



The cabin is fitted as standard with 12V LED ceiling lights which run off battery power only and do not require generator or external power. The Battery Isolator switch must be in the ON position for all LED lights to function.

The lights within your canteen (and office/drying room if applicable) are operated via a switch on the wall.

The 12V LED ceiling lights in the toilet(s) and generator/drying room are operated via PIR sensor so there is no need to switch on, they will come on automatically as someone enters the room.

5C.4.2 USB CHARGING POINTS



12V USB charging points are provided to enable mobile phones, tablets and notebooks to be charged from the battery. Switch the Cabin Power Isolator switch to the ON position to use.

5C.4.3 POWER SOCKETS



The ECO HYBRID unit is equipped with a number of low power inverted power sockets (red sockets) suitable for powering computers and printers, etc. These run on battery power only and can be used without generator or external power. The Cabin Power Isolator switch must be ON.

The ECO HYBRID is also equipped with ordinary 230V power sockets (white sockets). To use these, you need generator or external power. The Cabin Power Isolator switch must be ON and the Power Selector Switch in Position 1.

5C.4.4 KITCHEN APPLIANCES



The unit's food preparation area is supplied as standard with a kettle to make hot drinks and a microwave for hot food preparation. To use these, you need generator or external power. The Cabin Power Isolator switch must be ON and the Power Selector Switch in Position 1. If either of them does not appear to be working, make sure their dedicated power switch is in the ON position.



5C.4.5 INSTANT HOT WATER HAND WASH UNIT



The hand washer heater draws water from a fresh water container located beneath the sink. Always ensure that there is sufficient water in the fresh water container.

To operate the instant hot water hand wash unit in an ECO HYBRID unit, you need generator or external power. The Cabin Power Isolator switch must be ON and the Power Selector Switch must be in Position 2.

To start the unit, simply turn the dial to the required temperature. The water is heated instantly and starts to flow. The temperature of the water can be controlled by turning the dial from 1 – Cool to 10 – Hot.

CAUTION

Do not let the hand wash unit be run dry as this will result in damage to the unit.

Make sure the water heater on/off switch is switched on. This is located under the sink.

CAUTION

To avoid scalding set the water temperature to cool at start of use and gradually increase as required. Allow the water to run for a few seconds before use.

5C.5 USING THE HEATERS

Your ECO HYBRID welfare cabin will be fitted with one or more of the following types of heater. Please follow these instructions on how to operate.

5C.5.1 PLINTH HEATER



CAUTION

Use of the heaters with other electrical equipment may overload the generator capacity.

Using the plinth heater requires generator or external power. The Cabin Power Isolator switch must be ON. The Power Selector Switch can be in any position – 0, 1 or 2.

The switches to operate the plinth heater are situated on the front of the unit. The top switch turns the heater on and off. The lower switches control the temperature. Press the left hand switch for Low heat and the right hand switch for High.

If required, the master switch for the plinth heater is located beneath the bench seat cushion.

5C.5.2 FAN HEATER



Using the fan heaters requires generator or external power. The Cabin Power Isolator switch must be ON. The Power Selector Switch can be in any position – 0, 1 or 2. Make sure the Fan Heater wall switch is on. Pull the string handle to switch on or off. The fan heater is not thermostatically controlled.

The fan heater is protected by its own MCB in the distribution board.

5C.5.3 12V WEBASTO DIESEL/HVO HEATER



A 12V Webasto diesel/HVO heater is fitted as standard on all ECO HYBRID specified units. The Webasto does not need generator or external power to operate. The Cabin Power Isolator switch must be ON.

The Webasto Heater unit uses a temperature sensor to monitor the temperature within the welfare unit. The temperature can be controlled by adjusting the dial. Turn to the right to switch on and increase temperature and left to decrease temperature and switch off.

The actual Webasto heater unit is usually located beneath the bench seating in the cabin.

 **NOTE**

When the Webasto is operating correctly, there should be a solid green light in the centre of the control dial. If this light is flashing, it means there is a fault. Please refer to the Webasto Operation Manual if this occurs.

5C.6 ELECTRICAL INSTALLATIONS

5C.6.1 FUSE BOX (230V DC DISTRIBUTION)



With the ECO HYBRID system, the distribution board is usually located in the canteen area of the welfare unit. It will contain a RCD Main switch and Test button, and individual MCBs to protect the electrical circuits for the vehicle.



To test the Main RCD open the cover and ensure the RCD paddle is in the “ON” position. Press the TEST button, the paddle will move to the down “OFF” position and power will be cut to all circuits. If this does not happen, the RCD is faulty and the electrical system should not be used until rectified by qualified personnel. To reset the RCD or any MCB push the paddles to the “ON” position.

5C.6.2 BATTERY



Your ECO HYBRID specified cabin is fitted with a 145Ah battery which is located beneath the bench seating in the canteen area.

5C.6.3 BATTERY CHARGER



The AGM battery charger is located beneath the bench seating in the canteen area. The battery charger is fitted with an ON/ OFF switch. This should be in the ON position at all times. A red light illuminated on the charger indicates it is charging the batteries, a green light indicates that the charge is complete. The battery charger is automatically operated.

5C.6.4 BATTERY CHARGER ISOLATOR



The Battery Charger Isolator switch is located beneath the bench seating. Press the button to turn off the power supply to the battery charger if required.

5C.6.5 LOAD SHEDDER

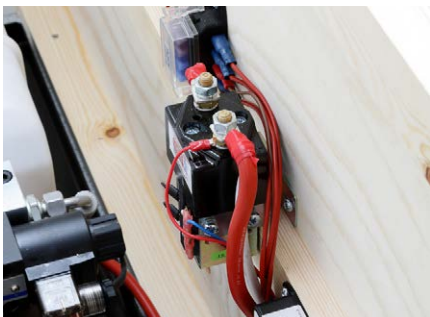

The load shedder is located beneath the bench seating in the rest room area. The load shedder protects the charge in the battery and isolates all 12V electrics when the battery voltage falls below a predetermined value. This ensures there is always sufficient power to start the generator and operate the electric hydraulic rams.

5C.6.6 SMART GAUGE



In ECO HYBRID specified units, a Smartgauge is fitted. The Smartgauge automatically turns on the generator when the battery level is low and charges the battery making sure that the battery is constantly topped up with power. It automatically shuts down the generator when the battery charge cycle is complete

The Smartgauge control panel provides a reading of the charge state of the batteries. To determine the battery voltage press button **[a]**, the voltage will be shown in the LED display. To show the charge status (%), press button **[b]**. Button **[c]** is not used in this installation. When the Smartgauge runs the generator “ALS” will be displayed and the red LED **[d]** will illuminate. In this state it will not be possible to stop the generator with the remote panel.

INSIDE YOUR WELFARE UNIT



Here is a guide to the non-electrical features of your Calnan mobile welfare unit. See Manual Section 5 for a guide to all electrical features.

6

6.1 DRINKING WATER



The unit is equipped with a 20l drinking water tank with a tap. This is stored in a wall bracket in the kitchen area of your canteen. During towing, the tank should be empty. To fill, lift the tank from its bracket, fill with either tap or bottled water fit for human consumption, replace the cap. Place the tank back where this is in its bracket and secure with the strap if one is provided.



NOTE

The container must only be used for drinking water and must be emptied and cleaned regularly. If used for any other purpose it must be replaced.



CAUTION

Each water tank weighs 20-25kg when full. Take care while lifting. To prevent injury, use suitable lifting techniques or seek assistance when replacing.

6.2 HAND WASH WATER TANK



A clean water container beneath the sink supplies the hot hand wash unit. When refilling, remove the tube and replace the cap before taking the container out. Fill with clean water suitable for hand washing. Replace in the mounting, refit the tube and test the operation. Always ensure that there is sufficient water in the fresh water container.



CAUTION

Do not let the hand wash unit be run dry as this will result in damage to the unit.

For information on how to operate the Hot Wash unit, please refer to Manual Section 5.

6.3 WASTE WATER TANK



Waste water from the sink is drained into the waste water container beneath it. When removing the container remove the drain tube and replace the cap. Lift the container from its mounting and take for disposal. Refit the empty container and ensure the drain tube from the sink is replaced in the container.

6.4 SOAP DISPENSER



Place your hand beneath the unit and press the button to dispense soap. The soap dispenser uses 2 litre sealed pouch cartridges to minimise spillage, waste and cross- contamination. Follow the manufacturer's instructions to replace the soap cartridges.

6.5 PAPER TOWEL DISPENSER



The paper towel dispenser dispenses C or Z fold towels. Place your hand beneath the unit and push the bar upwards to dispense towels. Follow the manufacturer's instructions to replace the towels in the dispenser.

6.6 DRINKING CUP DISPENSER



To dispense cups pull the exposed part of the cup from the bottom of the dispenser. To re-fill open the top and insert cups. Please remember the environment and fill with paper cups, not plastic.

6.7 FOOD PREPARATION



The unit's food preparation area is supplied as standard with a kettle to make hot drinks and a microwave for hot food preparation. For information on how to power these appliances correctly according to your electrical specification, see Section 5 of the manual.

6.8 CARBON MONOXIDE ALARM



The cabin is fitted with an audible carbon monoxide alarm. If the alarm sounds, leave the unit immediately. Turn off the cabin and evacuate it. If necessary take specialist advice to determine the source of the contamination. Do not re-enter the cabin until it is safe to do so.

The monitor should be tested at regular intervals. Please refer to the Manufacturer's Operating Manual for instructions on how to carry out these tests.

6.9 BENCH SEATING



The seat pads of the bench seating in the canteen and office area (if applicable) may be cleaned by wiping down with clean water and a mild detergent. All the bench seat pads can be lifted off for deeper cleaning.

Stored within some benches is electrical equipment such as the battery, hydraulic ram machinery, etc. You will also find the remote control for the hydraulic rams and the props.

6.10 DEDICATED STORAGE



In all welfare cabins apart from the 6-man Canteen Space 12 unit, there is generous dedicated storage space under the some of the bench seating for boots and tools. The areas under other benches are used to house equipment and components. Please do not store items in these other underseat areas where equipment is installed.



Some models of cabin are also equipped with wall-mounted storage compartments to ensure there is adequate space for workers to store their clothes and equipment without causing trip hazards on the floor.

6.11 WINDOWS AND SHUTTERS



There are one or more sliding window in your cabin. To open the window(s), release the latches and slide the glass panel open.



CAUTION

When leaving the unit unattended and when towing ensure the security shutters are closed and the window is shut and latched.



The windows are protected by steel security shutters which are locked internally and can only be opened from inside the unit. To open, release the lockbolt and push the shutters open. There is a catch on the outside of the unit to hold them back in position.



CAUTION

The security shutter is heavy and may move suddenly if on uneven ground or when windy. Take care to avoid trap injuries to hands and fingers when opening or closing the shutters.

6.12 MAGNETIC DOOR STAYS



NOTE

Unlike traditional metal door stays where you have to remember to disengage the stay, with the magnetic stay there is no risk of damage either to the stay or to the door if the door is slammed or pulled with too much force.

CAUTION

Beware of the step when leaving the cabin.

You will notice your cabin is fitted with a magnetic door stay. This is a robust magnetic mechanism for holding the door open. In the fully open position this will engage automatically. To close the door, disengage the mechanism simply by firmly pushing or pulling the door towards its closed position.

6.13 DOOR LOCKS



The cabin doors are locked by moving the slider to the locked side and then locking with the key.

USING YOUR TOILET



Depending on the model specified, your cabin has one or two toilet compartments and will be fitted with either a recirculating chemical toilet(s) or a fresh water micro flush toilet(s).

Please go to one of the following sections depending on your toilet type:

- 7A Recirculating Chemical
- 7B Fresh Water Flush

7

7A USING YOUR TOILET CHEMICAL



Your welfare cabin is fitted with a recirculating chemical toilet with integrated wash basin unit.

7A.1 TOILET



The recirculating chemical toilet is a self contained unit which uses special fluids for flushing. See 7A.8.3 for advice on filling and emptying.

To operate the toilet flush after use, move the pump lever back and forth until the toilet bowl is clear.

7A.2 HAND WASH BASIN



The hand wash basin in the toilet has its own clean water reservoir held within the base pillar. See 7A.8 for advice on filling and emptying.



To use the tap, depress the pump button at the base of the unit repeatedly with your foot. If no water emerges, check the water level in the reservoir and refill. See 7A.8 for instructions on how to do this.

7A.3 INSTANT HOT WASH



NOTE

If the reservoir is empty and there is no water flow to the hot wash unit, it will not operate. It will run the pump for a short period of time and then switch off. If this occurs, check and refill the water reservoir. See 7A.8 for instructions on how to do this.

To operate the toilet's instant hot wash facility:

For STANDARD, ECO+ and ECO HYBRID electrical specifications, make sure the Power Selector Switch in the Canteen is set to Position 2. Then switch on the Water Heater in the toilet. Turn the dial for instant hot water or if you have a hands-free unit, swipe your hand in front of the sensor on the front of the unit to start the washer and then again to stop it.

For ECO ULTIMATE specification, simply make sure the Water Heater wall switch is on then turn the dial or swipe your hand and the unit will function.

7A.4 DISPENSERS



The toilet cubicle is fitted as standard with a toilet roll holder plus soap and paper towel dispensers. To fill your dispensers, please check the instructions for the canteen dispensers in Section 6. Some toilets may also be fitted with a hand sanitiser dispenser.

7A.5 PIR-SENSOR CONTROLLED 12V LED LIGHTING



The toilet compartment contains a PIR operated ceiling light. The light will operate when a person enters the toilet room, and will turn off when the person leaves the compartment.

7A.6 HEATER



The toilet compartment is equipped with a fan heater. To operate turn on the wall mounted Fan Heater isolator switch. Pull the cord to switch on or off. The unit is not thermostatically controlled.

7A.7 TOILET DOOR LOCKS



To lock the door from inside the toilet/washroom compartment, first use handle to close the door firmly. Next move the slider fully to the left, then push in the plunger to lock.

To unlock, pull the plunger out and move slider fully to the right. Use handle to push the door open.



There are safety locks on the toilet doors which means that as well as the usual internal lock, there is an external key-operated lock to allow access in case of an emergency.



Emergency Unlocking Procedure

From outside the toilet/washroom compartment use the key to unlock the door. This will release the plunger. Move slider to the right and this will release the door.

7A.8 RESERVOIR TANKS

7A.8.1 CLEAN WATER RESERVOIR – FILL



To fill the clean water reservoir in the hand wash basin, remove the filler plug adjacent to the bowl on the right hand side. Fill the reservoir with fresh clean water and replace the filler plug.



CAUTION

The vehicle should never be towed with water in either the clean water reservoir or the toilet reservoir as this may cause the vehicle to become unstable and overweight. Always make sure the tanks are drained before towing the unit.

7A.8.2 CLEAN WATER RESERVOIR – DRAIN



Before towing the unit, any water in the clean water tank must be removed. There are two ways to drain the tank. Either by depressing the foot pedal and running all water out of the reservoir into the sink from which it will move to the waste tank. Or you can remove the white drain plug from the base of the sink and the water will run out from there.

7A.8.3 TOILET RESERVOIR



Filling and emptying the toilet reservoir should always be undertaken by a specialist company. Please contact the supplier for further details.

7B USING YOUR TOILET

FRESH WATER



Your welfare cabin is fitted with a fresh water micro-flush toilet and a stainless steel hand wash basin.

7B.1 TOILET



Your cabin is equipped with a toilet with fresh water micro flush. To operate the toilet flush, raise the flush lever to add water to the toilet before use, then after use hold down the flush lever until the contents leave the toilet. Allow the flush lever to snap back which permits positive sealing around the flush ball. A small amount of water should remain in the bowl.

7B.2 HAND WASH BASIN



Units with fresh water toilets are fitted with stainless steel sink basins. The water for the hand wash basin is pumped automatically from the clean water reservoir to the instant hot water unit. If there is no water in the clean water tank, the pump will not operate. See 7B.7 for how to check and fill the tank.

7B.3 INSTANT HOT WASH



To operate the toilet's instant hot wash facility:

For STANDARD, ECO+ and ECO HYBRID electrical specifications, make sure the Power Selector Switch in the Canteen is set to Position 2. Then switch on the Water Heater in the toilet. Turn the dial for instant hot water or if you have a hands-free unit, swipe your hand in front of the sensor on the front of the unit to start the washer and then again to stop it.

For ECO ULTIMATE specification, press the Water Heater switch in the toilet to the 'on' position.

Then turn the dial or swipe your hand and the unit will function.

7B.4 DISPENSERS



The toilet cubicle is fitted as standard with a toilet roll holder plus soap and paper towel dispensers. To fill your dispensers, please check the instructions for the canteen dispensers in Section 6. Some toilets may also be fitted with a hand sanitiser dispenser.

7B.5 PIR-SENSOR CONTROLLED 12V LED LIGHTING



The toilet compartment contains a PIR operated ceiling light. The light will operate when a person enters the toilet room, and will turn off when the person leaves the compartment.

7B.6 TOILET DOOR LOCKS



To lock the door from inside the toilet/washroom compartment, first use handle to close the door firmly. Next move the slider fully to the left, then push in the plunger to lock.

To unlock, pull the plunger out and move slider fully to the right. Use handle to push the door open.

There are safety locks on the toilet doors which means that as well as the usual internal lock, there is an external key-operated lock to allow access in case of an emergency.

Emergency Unlocking Procedure:

From outside the toilet/washroom compartment use the key to unlock the door. This will release the plunger. Move slider to the right and this will release the door.

7B.7 RESERVOIR TANKS



When the fresh water toilet system is chosen, a fresh water reservoir is installed and also a waste tank. Water from the fresh water reservoir supplies the self contained toilet and the hand wash basin automatically by means of an electric pump.

When in use, the water levels in the clean water reservoir and the waste water tanks are monitored. The monitor gauges are found in the toilet compartment.

When the level in the clean water tank falls to a critical level, the lamp will illuminate.

The waste water level is monitored by the gauge. Press the READ button to read the level of the contents in the waste water tank.

If the level is above $\frac{3}{4}$ ensure the waste water tank is emptied.

7B.7.1 CLEAN WATER RESERVOIR – FILL



The filler is located on the left side of the trailer at the rear.

Before filling, ensure the area around the filler is clean and free of any contamination or debris.

Use the key (located in the document holder inside the cabin) to remove the clean water reservoir cap



Fill the reservoir from a suitable supply. Continue filling until the water overflows from the reservoir filler. When full replace and lock the cap. Replace the tool in the document holder inside the cabin.

CAUTION

The vehicle should never be towed with water in either the clean water reservoir or the toilet reservoir as this may cause the vehicle to become unstable and overweight. Always make sure the tanks are drained before towing the unit.

7B.7.2 CLEAN WATER RESERVOIR – DRAIN



Before towing the unit any water in the clean water tank must be removed. The drain for the clean water tank is located on the underside of the trailer towards the rear, beneath the toilet compartment.

Use a suitable tool to remove the drain plug from the tank and drain the water into a suitably sized container. Dispose of the water drained from the tank and replace the drain plug.

7B.7.3 WASTE WATER TANK – DRAIN



When more than 3/4 full or before towing, any waste in the waste water tank must be removed.

The waste water is pumped out from the connector located inside the toilet compartment in the floor.

Remove the cover. Connect the equipment to the drain and remove the waste. Replace the cover.

CAUTION

The waste water tank contains biological and chemical waste from the toilet and should only be removed by suitably trained personnel using specialist equipment. It is an offence to discharge waste into surface or domestic drainage systems.

MAINTENANCE



The following section identifies items on the welfare unit that will from time to time require maintenance. Some of these can be carried out by the user, whilst others may need to be undertaken by suitably qualified and experienced technicians.

8



WARNING

- Never work beneath any unsupported load or structure.
- Always move the vehicle to a safe place away from traffic or site equipment before attempting maintenance.
- Never climb on or work over or above any device without suitable fall restraint equipment.
- Ensure the unit is parked on firm level ground before changing wheels.
- Always take care when working with or connecting any electrical equipment. Damaged or inadequately insulated equipment can lead to electrocution causing fire, burns, serious injury or death.
- Always follow instructions.
- If in doubt ask for assistance from suitably qualified personnel.
- Always abide by the work site's published Safety Policy.

8.1 CHANGING A WHEEL

If you suffer a puncture whilst towing, follow these instructions to enable you to change or repair a wheel.

8.1.1 PREPARATION



1. Make sure the unit is disconnected from the towing vehicle. Remove the hydraulic cylinder props from their storage compartment. Depending on your ram configuration, there will be either 2 or 4 cylinder props inside a bench unit in the cabin.



2. Raise the cabin using the lift cylinders (rams) until the wheels are clear of the ground. For instruction how to do this, go to Manual Section 3.4 and follow the first steps. Once the wheels are raised, place the cylinder props on each leg of the cabin.



3. Secure the cylinder props using the pin and clip.



IMPORTANT

You must use one prop on every cylinder (ram) of your cabin.

8.1.2A FOR NEWER MODELS WITH DETACHABLE WHEEL ARCH



1. With the unit suitably supported, remove the screws that secure the wheel guard panel and withdraw it from the side of the cabin.



2. Loosen the wheel nuts and remove the wheel.

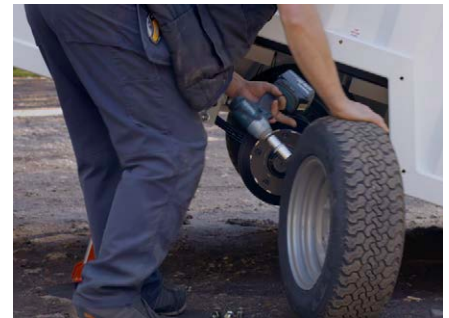

3. Repair the wheel or replace with a suitable spare.



4. Refit the wheel nuts and tighten to 160Nm.



5. To refit the wheel arch, reverse the removal procedure and replace all screws.



6. Remove the cylinder props. Use the hydraulic system to lower the cabin back onto its wheels and then replace the props and hydraulic remote control back in their stowed positions inside the cabin.

8.1.2B FOR EARLIER MODELS WITHOUT DETACHABLE WHEEL ARCH



3 2 1

1. Remove the red cylinder props from their storage position within the cabin.

2. With the cabin still lowered and wheels on the ground, remove the lower retaining bolts [1] from the leaf spring [2] mounting plate on both sides of the cabin so the entire axle [3] is released. The bolt is the one in front of the wheel under the locking pin.

3. Then raise the cabin using the electric hydraulic system to its highest point and secure the cabin in the raised position using the cylinder props (see Manual Section 8.1.2A for instructions).

4. As you have released the axle, the wheels and axle will remain on the ground. Use a jack to lift the axle [3] so that the wheels lift slightly off the floor.

5. Loosen the wheel nuts and remove and replace the wheel, tightening the wheel nuts to 160Nm.

6. Remove the jack from under the axle so the wheels are on the floor.

7. Remove the cylinder props from the rams and lower the cabin back down onto the wheels.

8. Refit the lower retaining bolts to the leaf spring mounting plate and torque to 25 Nm.

9. Replace the red cylinder props in their stowed position inside the cabin.

8.2 BRAKE SETTING PROCEDURE – PREPARATION SINGLE AND TWIN AXLE



CAUTION

Make sure the unit is on level ground to carry out this procedure.



1. Remove the hydraulic cylinder props from their stowage compartment. Depending on your ram configuration, there will be either 2 or 4 cylinder props inside a bench unit in the cabin.

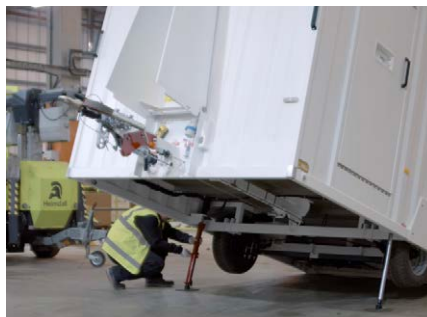

2. Raise the unit using the lift cylinders (rams). For instruction how to do this, go to Manual Section 3.4 and follow the first steps. Once the wheels are raised, place the cylinder props on each leg of the cabin.



3. Secure the cylinder props in place using the pin and clip.



IMPORTANT

You must use one prop on every cylinder (ram) of your cabin.



4. Release the parking brake and ensure the draw tube is fully extended out of the over run coupling.



CAUTION

During brake setting, only rotate the wheels in a forward direction. Also do not use the brake rod as a means of adjusting the brakes.

8.2A BRAKE SETTING PROCEDURE

SINGLE AXLE

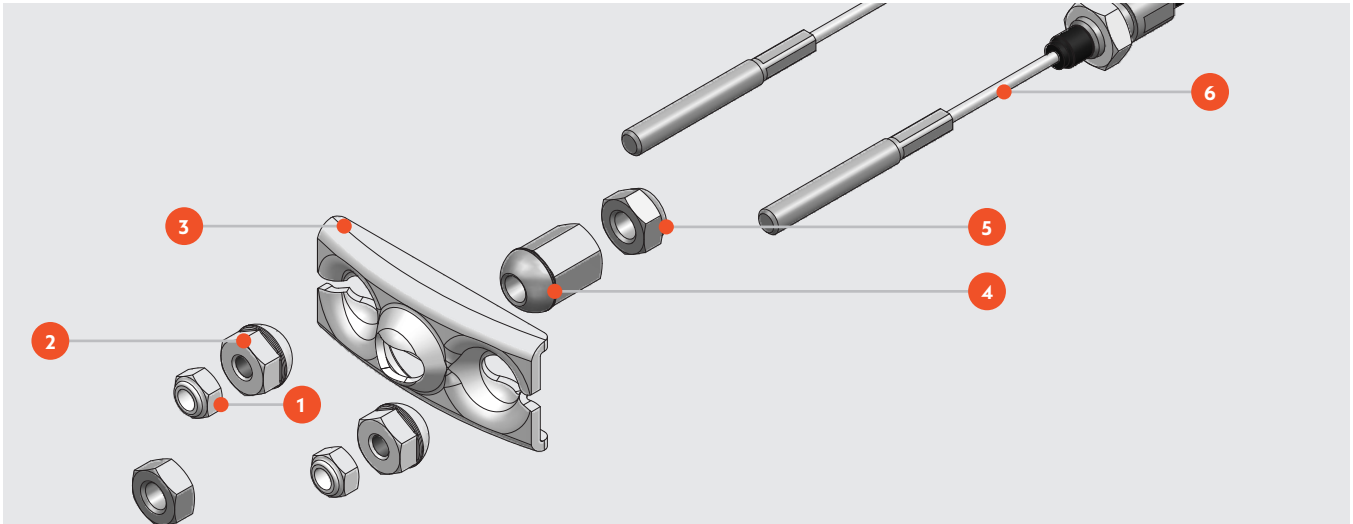

- 1. Brake cable outer locknut
- 2. Brake cable spherical nut
- 3. Brake cable compensator bar
- 4. Brake rod spherical nut
- 5. Brake rod outer locknut
- 6. Brake cable

1. Check that the brake cables are not under tension, if necessary reduce this tension by adjusting the spherical nuts at the ends of the cables on the cable compensator bar.

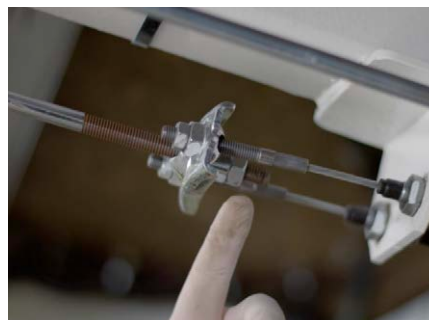

2. Check that the brake rod is not under tension, if necessary reduce the tension by adjusting the spherical nut at the end of the rod on the cable compensator bar.



3. To set the Wheel Brakes, tighten the adjusting screw on the rear of the brake unit back plate (clockwise) until it is not possible to turn the wheel by hand. Turn the adjusting screw back (counter clockwise) by approx 1/2 a turn (180 deg) or until the wheel turns freely by hand. Make sure you are turning the wheel in a forwards direction. Repeat this for each wheel.



NOTE

Some slight “grinding noises” which do not impede the movement may be heard, this is normal.



4. Next set the Cable Compensator Bar. This bar must be aligned perpendicular (90°) to the direction of travel. Once in position secure the position using the spherical nuts, then tighten the outer lock nuts onto the spherical nuts.

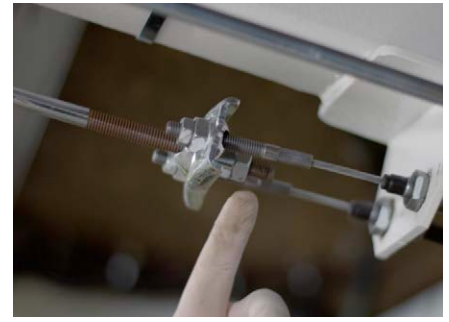

5. Next set the Brake Rod. Adjust the brake rod by tightening or loosening the adjusting spherical nut until there is neither tension or free play in it. Once the spherical nut is holding the brake rod correctly, then tighten the outer lock nut onto the spherical nut to secure.



WARNING

If the wheels have inadvertently been rotated backwards, the auto reverse mechanism may have been activated. If this is the case or the brakes do not operate correctly, check for faults and repeat the whole procedure.



6. Finally set the Parking Brake Lever. Firmly activate the handbrake repeatedly in order to re-seat the braking components. When applying the handbrake lever do not force it further back than its normal rest position.



7. Check the orientation of the Cable Compensator Bar beneath the cabin again, making sure that it remains in position, perpendicular to the direction of travel. Then move handbrake lever to the desired position so that all three pivots are in line as shown in this image.

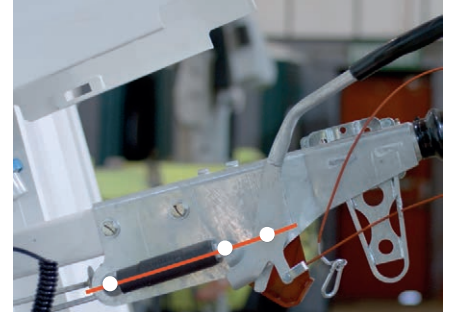

8. Check that the brake reaction lever is in contact with the handbrake lever and has 10–15mm of movement away from the handbrake lever when it is pushed manually.

8.2B BRAKE SETTING PROCEDURE

DOUBLE AXLE

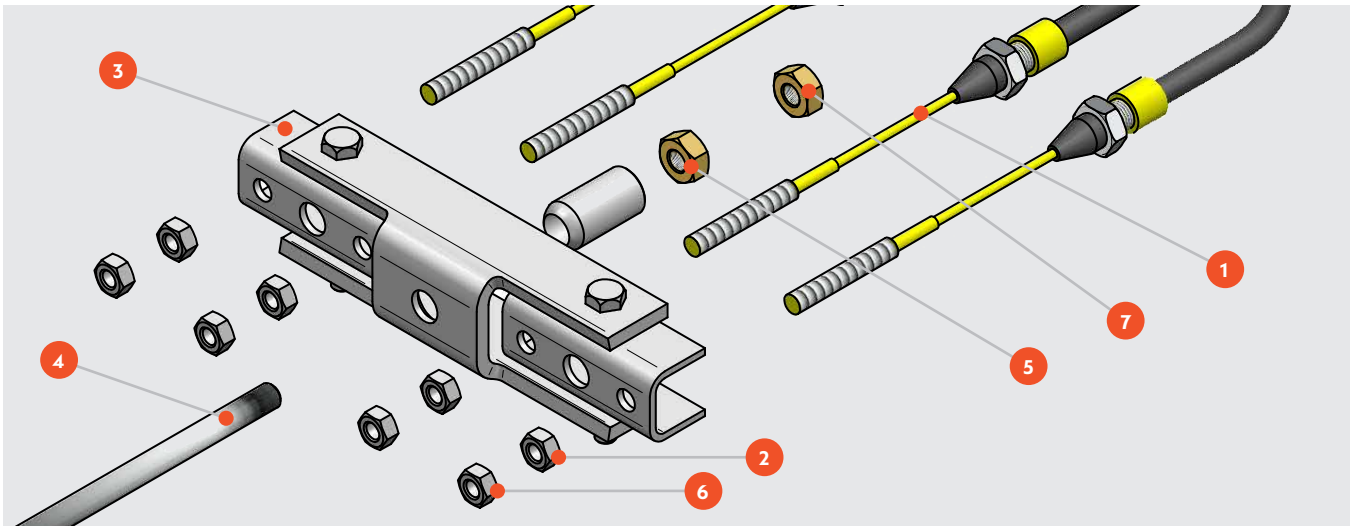

1. Check that the brake cables [1] are not under tension, if necessary reduce this tension by adjusting the spherical nuts [2] at the ends of the cables on the cable compensator bar [3].

2. Check that the brake rod [4] is not under tension, if necessary reduce the tension by adjusting the spherical nut [5] at the end of the rod behind the cable compensator bar [3].

3. To set the Wheel Brakes, tighten the adjusting screw on the rear of the brake unit back plate (clockwise) until it is not possible to turn the wheel by hand. Turn the adjusting screw back (counter clockwise) by approx 1/2 a turn (180 deg) or until the wheel turns freely by hand. Make sure you are turning the wheel in a forwards direction. Repeat this for each wheel. See image in Section 8.2A for clarification.

4. Next set the Brake Cable Compensator Bar [3]. This bar must be aligned perpendicular (90 degrees) to the direction of travel. Once in position tighten the 4 lock nuts [6] onto the 4 spherical nuts [2] attached to the brake cables.

5. Next set the Brake Rod. Adjust the brake rod by tightening or loosening the adjusting spherical nut until there is neither tension or free play in it. Once the spherical nut [5] is holding the brake rod [4] correctly, then tighten the outer lock nut [7] onto the spherical nut to secure.

6. Finally set the Parking Brake Lever. Firmly activate the handbrake repeatedly in order to re-seat the braking components. When applying the handbrake lever do not force it further back than its normal rest position.



WARNING

If the wheels have inadvertently been rotated backwards, the auto reverse mechanism may have been activated. If this is the case or the brakes do not operate correctly, check for faults and repeat the whole procedure.



NOTE

Some slight "grinding noises" which do not impede the movement may be heard, this is normal.





7. Check that the orientation of the Cable Compensator Bar – all three pivots should be in line as shown.

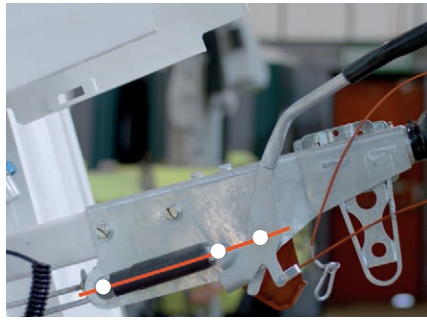

8. Check that the brake reaction lever is in contact with the handbrake lever and has 10–15mm of movement away from the handbrake lever when it is pushed manually.

8.3 BRAKE CHECK AND TEST



ROAD TEST A

- 1.** Drive in a straight line at 20/25 mph; apply the brakes gradually and firmly to produce a smooth stop.
- 2.** Observe the behaviour of the cabin during braking (this may be more easily done by a passenger in the towing vehicle rather than the driver).
- 3.** If the cabin is pulling to one side under braking or the wheels are locking up on one side, the system **MUST** be checked and reset before proceeding. Once smooth straight line braking is achieved at this speed, proceed to Road Test B.

 **CAUTION**

Ensure that any testing carried out on public or private roads is done taking due account of other road users.

 **NOTE**

All braking should be gradual and sympathetic to the system. Aggressive and violent braking should be avoided during these procedures in order to safely judge the braking performance and obtain optimum bedding in of the brake linings.

ROAD TEST B

- 1.** Drive in a straight line at 35/40mph (assuming speed limits allow) and apply the brakes firmly and steadily without locking up the trailer wheels.
- 2.** Once again observe the behaviour and handling of the cabin under braking and, as in Road Test A, readjust the system if braking is not even on both sides.

ROAD TEST C

- 1.** Finally drive at 50mph (if speed limits allow) and apply the brakes to reduce speed to 30mph, accelerating back to 50mph.
- 2.** If satisfied that the cabin is braking evenly and steadily, repeat the manoeuvre 3 or 4 times.

BEDDING IN THE BRAKES

The brake linings will wear in, improving in performance as they take on the contours of the drum. They will also generate heat which in turn will optimise the coefficient of friction on the linings and provide improved braking performance as they “bed in”. Dependent on the type of driving style used, the brakes may not achieve optimum efficiency either in overrun or on the brake lever for 500 miles. Stop/start driving will bed the brakes in more quickly than motorway driving where the brakes are hardly used.

In the event of the shoes adhering to the drum it will be necessary to release them using the following procedure:

- 1) Turn the adjuster bolt anticlockwise by approximately half a turn.
- 2) Tap the bottom of the back plate using a soft faced or wooden mallet.
- 3) If the brake shoes have not released, jack up the trailer as described earlier in this manual.
- 4) Remove wheel assembly.
- 5) Tap brake drum with mallet.
- 6) Once the brake shoes have released, readjust the brake.

Please note that there may be corrosion within the drum that has been a contributory factor to the brake linings sticking. It is recommended as good practice to therefore remove the drums and clean them before the cabin is once again parked. Frequent use of the overrun brakes should ensure that the drum surface remains free of corrosion.

Brakes should be readjusted as often as is necessary. There is no set time or distance limit. Users should check the slack in the system before each journey and readjust accordingly. Most couplings have 90 or 100mm of travel through the drawtube (connecting rod) and damper. The simplest way to check the slack on most systems is to push the bottom of the brake reaction lever forward and if the movement is more than half of the coupling travel, i.e. 45 or 50mm, it is recommended that the brakes are readjusted.

A service should also be performed on the braking system at regular intervals. The timing of this may depend on the use of the cabin, in terms of distance and driving style.

Cabins that are for occasional use only should also be checked to ensure that no parts have seized. During these service checks the drums should be removed and the brakes checked for damage and wear. Linings should be replaced if there is less than 2mm lining thickness left on the shoe. This should ensure that the linings do not wear out before the next service.



IMPORTANT

During the bedding in process the properties at the surface of the lining change. Until the brakes are bedded in according to this recommended procedure there is a possibility that the brake shoes may adhere to the brake drum surface when parked with the handbrake lever in the “on” position.

Since the introduction of asbestos-free brake linings this has been found to occur with ALL makes of lining material. It is therefore recommended that, if the cabin is to be parked for extended periods or in damp or humid conditions, the wheels are chocked and handbrake lever released.

In addition, it is also good practice, if reversing the cabin into position, to draw the cabin forward slightly before leaving. This ensures that the brake shoes have returned to their normal running position.

8.4 SERVICE CHECKS

NOTE: An annual safety checking service is available.

	Daily	Weekly	Monthly	6 months	Annual	Before transporting	Before use on arrival to site	Manual section
Check and fill drinking water container (canteen) or empty if transporting	X					X	X	6.1
Check and fill clean water tank (canteen) or empty if transporting	X					X	X	6.2
Check and remove waste water (canteen)	X					X		6.3
Replenish water cups	X						X	6.6
Check and fill dispensers – hand towels, soap and sanitiser	X						X	6
Check and refill generator fuel level	X						X	4.3
Check generator engine oil level (Redbox)	X						X	4.3
Check generator engine oil level (Redbox Infinity)		X					X	4.3
Check and fill fresh water tank (chemical toilet) or empty if transporting		X				X	X	7A.8
Check fresh water / waste water levels (fresh water toilet)		X				X	X	7B.8
Check CO monitor function		X					X	6.8
Check CO monitor sensor			X				X	6.8
Check electrical system function (RCD board)				X			X	8.5
Check security of door and window locks	X					X	X	6.11
Check operation of anti vandal cover						X	X	3.5
Check for wear in drawbar coupling					X			
Remove internal door panels and grease moving parts of door locking mechanisms					X			
Check for corrosion and mechanical defects in braking system					X			
Check tyre inflation					X	X		8.1
Grease the axle locking pins and towing coupler					X	X		
Check brake setting/operation					X	X		8.2
Check brake function					X	X		8.3
Check tyre condition					X	X		
Check coupler function					X	X		3.2
Check function of all lights					X	X		
Check breakaway cable function					X	X		
Grease bright metal and other exposed parts					X	X		

Service Intervals	
Redbox	1000 hours (Hatz engine), 250 hours (Yanmar engine)
Redbox Infinity	2000 hours

8.5 ELECTRICAL CHECKS

In order to ensure correct function of the electrical system of your cabin and the safety of all operatives, there are certain electrical checks that should be carried out.

Some of these can be undertaken by the users, whilst others may need to be undertaken by qualified and suitably experienced technicians.



WARNING

- Always take care when working with or connecting any electrical equipment. Damaged or inadequately insulated equipment can lead to electrocution causing fire, burns, serious injury or death.
- Always follow instructions. If in doubt, ask for assistance from suitably qualified personnel.
- Always abide by the work site's published Safety Policy.

8.5.1A FUSE BOX CHECK ECO+, ECO HYBRID



Test Button On

According to BS7671 IET Wiring Regulations 18th Edition, the fuse box in your cabin should be tested every six months.

The distribution board is usually located in the canteen area of the welfare unit. It will contain a RCD Main switch and Test button, and individual MCBs to protect the electrical circuits for the vehicle.

To test the Main RCD open the cover and ensure the RCD paddle is in the "ON" position. Press the TEST button, the paddle will move to the down "OFF" position and power will be cut to all circuits. If this does not happen, the RCD is faulty and the electrical system should not be used until rectified by qualified personnel. To reset the RCD or any MCB push the paddles to the "ON" position.

DIAGNOSTICS



9

9A DIAGNOSTICS

ECO+, ECO HYBRID

Here we highlight a few issues you may encounter while using your cabin and give solutions on how to remedy them.

If at any point you have any questions or doubts, please do not hesitate to contact our Service Department.

To contact Calnan Service Department, call (021) 4820260 or email sales@calnan.ie

REFERENCES

While carrying out diagnostics on your cabin, you may need to refer to:

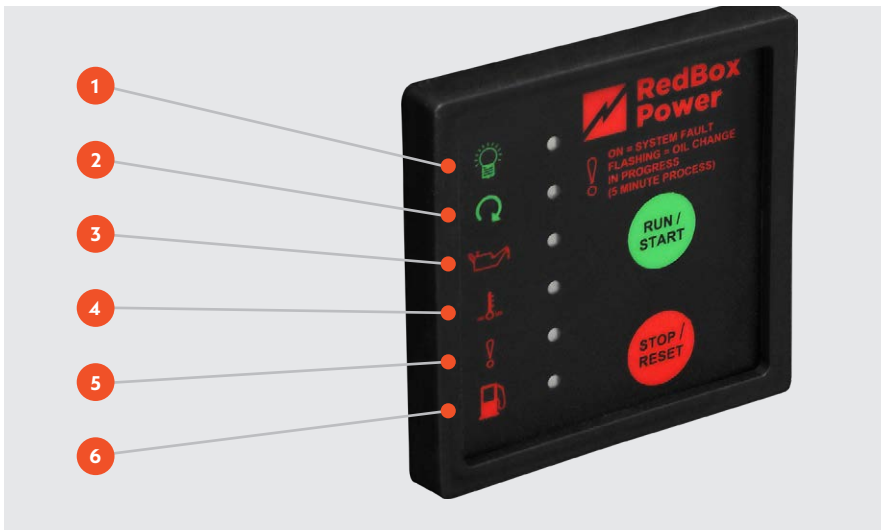

Generator Control and Status Panel (Canteen)

1. Power On
2. Running
3. Low Oil
4. High Temp
5. General Fault
6. Low Fuel



Generator Control Panel (Plant Room)

1. Grey lead to black socket
2. Breaker switches
3. Blue socket
4. Blue reset button
5. DSE display panel

9A.I GENERATOR NOT STARTING NO LIGHTS ON CONTROL PANEL

9A.I.1 CHECK CABIN POWER ISOLATOR SWITCH IN CANTEEN – IS IT ON?



YES – Go to Point 9A.1.2.
NO – Switch Cabin Power Isolator on, press green Start button on generator control panel.

Does generator start now?

YES – CONGRATULATIONS!
NO – Go to point 9A.1.2.

9A.I.2 ON THE GENERATOR, CHECK THE GREY LEAD IS PLUGGED INTO THE BLACK SOCKET?



YES – Go to point 9A.1.3.
NO – Plug the grey lead into the black socket.

Does generator start now?

YES – CONGRATULATIONS!
NO – Go to point 9A.1.3.

Grey cable

9A.I.3 CHECK BATTERY CABLES – ARE THEY CONNECTED CORRECTLY TO THE BATTERY?



The battery is located under the bench seat in the canteen.

YES – Go to Point 9A.1.4.
NO – Tighten the cables.

Does generator start now?

YES – CONGRATULATIONS!
NO – Go to Point 9A.1.4.

9A.1.4 CHECK THE BATTERY VOLTAGE ON THE DSE PANEL ON TOP OF THE GENERATOR



Press ▼ four times until you reach the Battery Voltage display.

Is the battery voltage showing as <12.2?

NO – Go to point 9A.1.5.

YES – Plug in an external power source. Turn the Internal/External Power switch in the canteen to Position 1 for external power and charge the battery. After charging the battery for an hour, recheck the DSE panel. Is the battery voltage now showing as >12.2?

NO – replace the battery.

Once battery is charged or replaced and voltage is showing as >12.2, try to restart the generator.

Does generator start now?

YES – CONGRATULATIONS! If you have an ECO HYBRID system, call to ascertain why your Smart Gauge has not automatically turned the generator on to charge the battery.

NO – Go to point 9A.1.5.

9A.1.5 CHECK STARTER MOTOR CABLES AT REAR OF ENGINE INSIDE GENERATOR – ARE THEY SECURE?



YES – Contact Calnan Service Department.

NO – Tighten the cables.

Does generator start now?

YES – CONGRATULATIONS!

NO – Contact Calnan Service Department.

9A.2 GENERATOR NOT STARTING CONTROL PANEL LIGHTS WORKING

9A.2.1 IF THESE LIGHTS ARE ILLUMINATED: POWER ON, LOW OIL, GENERAL FAULT

Check DSE display on top of generator in the Plant Room.

9A.2.1.1 IF DSE DISPLAY SHOWS: E STOP SYMBOL



If E-STOP is OUT – Contact Calnan Service Department.

If E-STOP is IN – Release the E-STOP
Press blue RESET button on generator

Does generator start now?

YES – CONGRATULATIONS

NO – Contact Calnan Service Department.

9A.2.2 IF THESE LIGHTS ARE ILLUMINATED: POWER ON, LOW OIL, GENERAL FAULT, LOW FUEL

Check DSE display on top of generator in the Plant Room.

9A.2.3.1 IF DSE DISPLAY SHOWS: FUEL SYMBOL



Top up with fuel.

Press blue **RESET** button on generator

Does generator start now?

YES – CONGRATULATIONS

NO – Contact Calnan Service Department.

9A.3 GENERATOR STARTS BUT CUTS OUT

9A.3.1 DID THE GENERATOR CUT OUT AFTER APPROX 50 MINUTES OF CONTINUOUS USE?

NO – Check for problems indicated in section 9A.1.

YES – If no fault lights are shown when the generator has switched off, this is a normal function of the generator in STANDARD, ECO+ and ECO HYBRID systems. An automatic timed cut-out is programmed into the generator to switch it off if users accidentally leave it running.

Press the green button to restart. Did the generator start and continue running now?

YES – CONGRATULATIONS!

NO – Check for problems indicated in section 9A.1.

9A.3.2 IF THESE LIGHTS ARE ILLUMINATED: POWER ON, LOW OIL, GENERAL FAULT

Check DSE display on top of generator in the Plant Room.

9A.3.2.1 IF DSE DISPLAY SHOWS: LOW V LOW HZ ICONS (FLASHING ALTERNATELY)



a) Check fuel filters – are they dirty?

NO – See b) below.

YES – Replace filters.

Press blue RESET button on generator.

Does generator start and continue running now?

YES – CONGRATULATIONS

NO – See b) below

b) Check fuel feed pipes / fuel tank for blockage – are they blocked?

NO – See c) below

YES – Clear blockage

Press blue RESET button on generator.

Does generator start and continue running now?

YES – CONGRATULATIONS

NO – See c) below

c) Check fuel quality – is the correct specified fuel being used?

YES – Contact Calnan Service Department.

NO – Change fuel to correctly specified quality fuel.

Press blue RESET button on generator.

Does generator start and continue running now?

YES – CONGRATULATIONS

NO – Contact Calnan Service Department.

9A.3.2.2 IF DSE DISPLAY SHOWS: ↑V



Press blue RESET button on generator.
Press ▼ once on DSE control panel and check generator voltage.
Are the volts showing as >259?

YES – Adjust idle speed to 3100 +10/-30.

Recheck the voltage.
Is it within accepted parameters (check Redbox manual for parameters)?
Does generator start and continue running now?

YES – CONGRATULATIONS

NO – Contact Calnan Service Department.

9A.3.2.3 IF DSE DISPLAY SHOWS: ↓V

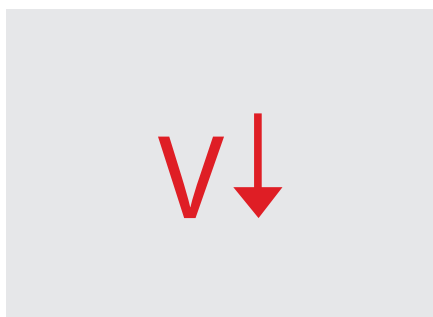

Press blue RESET button on generator.
Press ▼ once on the DSE panel and check generator voltage.
Are the volts showing as <190?

YES – Adjust idle speed to 3100 +10/-30.

Recheck voltage – is it correct?

NO – Contact Calnan Service Department.

YES – Does generator start and continue running now?

YES – CONGRATULATIONS

NO – Contact Calnan Service Department.

9A.3.3 IF THESE LIGHTS ARE ILLUMINATED ON THE GENERATOR CONTROL PANEL IN THE CANTEEN: POWER ON, RUNNING, GENERAL FAULT

9A.3.3.1 IF DSE DISPLAY SHOWS: OIL CAN



Check oil level in generator. For instruction on how to do this, go to Manual Section 4.3

Is the oil level correct?

YES – Contact Calnan Service Department.

NO – Top up the oil as described in Section 4.3 of the Operations Manual.

Press blue RESET button on generator.
Does generator start and continue running now?

YES – CONGRATULATIONS

NO – Contact Calnan Service Department.

9A.4 GENERATOR RUNS BUT NO 230V POWER TO CABIN

Are these lights illuminated on the generator control panel in the canteen?

- Power On
- Running

9A.4.1 IS IT JUST THE 230V SOCKETS AND FOOD PREPARATION APPLIANCES AFFECTED?

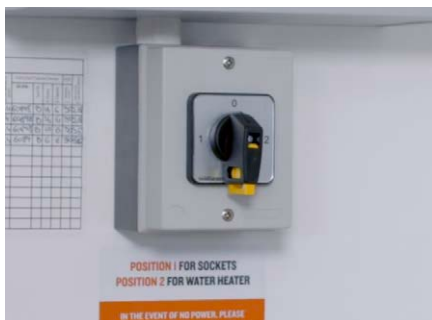

- NO** - Go to 9A.4.2
- YES** - Check if the Power Selector Switch the Canteen is in Position 1 for Sockets.
- YES** - Go to 9A.4.2
- NO** - Turn to Position 1. Do the 230V sockets work now?
- YES** - CONGRATULATIONS!
- NO** - Go to 9A.4.2

9A.4.2 CHECK BREAKER SWITCH UNDER THE FLAP ON THE CONTROL PANEL ON THE GENERATOR IN PLANT ROOM – IS IT ON?



- YES** - Go to 9A.4.3.
 - NO** - Turn it on
- Is there 230V power now?
- YES** - CONGRATULATIONS!
 - NO** - Go to 9A.4.3.

Breaker switch

9A.4.3 CHECK IN GENERATOR ROOM – IS CABLE CONNECTED TO BLUE PLUG SOCKET AT SIDE OF THE GENERATOR?



- YES** - Go to 9A.4.4.
 - NO** - Plug in.
- Is there 230V power now?
- YES** - CONGRATULATIONS!
 - NO** - Go to 9A.4.4.

Blue plug

9A – Diagnostics – Eco+, Eco Hybrid

9A.4.4 CHECK THE INTERNAL/EXTERNAL POWER SWITCH ON THE WALL AT FLOOR LEVEL IN THE CANTEEN – IS IT IN POSITION 2 FOR INTERNAL POWER?



YES – Go to 9A.4.5.

NO – Turn switch to Position 2

Is there 230V power now?

YES – CONGRATULATIONS!

NO – Go to 9A.4.5.

9A.4.5 CHECK RCD SWITCH IS ON (UP POSITION) – IS IT ON?



YES – Contact Calnan Service Department.

NO – Switch on.

Is there 230V power now?

YES – CONGRATULATIONS!

NO – Contact Calnan Service Department.

Test Button On

9A.5 NO 12V POWER IN CABIN ECO+ AND ECO HYBRID ONLY

9A.5.1 CHECK CABIN POWER ISOLATOR SWITCH IN CANTEEN – IS IT ON?

YES – Go to 9A.5.2

NO – Turn Cabin Power Isolator switch on

Do the 12V electric work now?

YES – CONGRATULATIONS!

NO – Go to point 9A.5.2.

9A.5.2 CHECK THE BATTERY VOLTAGE ON DSE DISPLAY ON TOP OF GENERATOR

To check battery voltage press ▼ four times. Are the volts showing as >12.2V?

YES – Contact Calnan Service Department

NO – Start and run generator to charge the battery.

Do the 12V lights and other 12V electrics work now?

YES – CONGRATULATIONS! If you have an ECO HYBRID system, call Calnan Service Department to ascertain why your Smart Gauge has not automatically turned the generator on to charge the battery.

NO – Call Calnan Service Department to reset the Load Shedder.

9A.6 WATER HEATER NOT WORKING CANTEEN

9A.6.1 IS GENERATOR ON?

YES – Go to 9A.6.2.

NO – Turn Cabin Power Isolator switch on.

Then press the green button to turn the generator on.

Does the water heater work now?

YES – CONGRATULATIONS!

NO – Go to 9A.6.2.

9A.6.2 IS THE POWER SELECTOR SWITCH IN CANTEEN IN POSITION 2 FOR WATER HEATER?

YES – Go to 9A.6.3.

NO – Turn Power Selector Switch to Position 2.

Does the water heater work now?

YES – CONGRATULATIONS!

NO – Go to 9A.6.3.

9A.6.3 IS THE WATER HEATER ISOLATOR SWITCH UNDER THE CANTEEN WORKTOP IN THE ON POSITION?



YES – Go to 9A.6.4.

NO – Turn Power Selector Switch to Position 2.

Does the water heater work now?

YES – CONGRATULATIONS!

NO – Go to 9A.6.4.

9A.6.4 SWITCH THE HEATER OFF – IS THE PUMP RUNNING?

YES – Go to 9A.6.5.

NO – If you have an Eco+ or Eco Hybrid unit, check and replace the pump. If you have a Standard unit, check and replace the transformer and/or the pump. Please contact Calnan Service Department if you need assistance with this.

Does the water heater work now?

YES – CONGRATULATIONS!

NO – Go to 9A.6.5.

9A.6.5 CHECK IF THERE IS SUFFICIENT WATER IN THE CLEAN WATER TANK?

YES – Contact Calnan Service Department.

NO – Fill the tank with clean water (see Manual Section 6.2 for instructions). Switch on water heater.

Does the water heater work now?

YES – CONGRATULATIONS!

NO – Contact Calnan Service Department.

9A.7 WATER HEATER NOT WORKING TOILET

9A.7.1 ARE THE CABIN POWER ISOLATOR SWITCH AND GENERATOR ON?

YES – Go to 9A.7.2

NO – Turn Cabin Power Isolator switch on. Then press the green button to turn the generator on.

Is there hot water now?

YES – CONGRATULATIONS!

NO – Go to 9A.7.2.

9A.7.2 IS THE WATER HEATER ISOLATOR SWITCH ON THE WALL IN THE TOILET IN THE ON POSITION?

YES – Go to 9A.7.3.

NO – Switch it on.

Does the water heater work now?

YES – CONGRATULATIONS!

NO – Go to 9A.7.3.

9A.7.3 SWITCH THE HEATER OFF – IS THE PUMP RUNNING?

YES – Go to 9A.7.4.

NO – If you have an Eco+ or Eco Hybrid unit, check and replace the pump. Please contact Calnan Service Department if you need assistance with this.

Does the water heater work now?

YES – CONGRATULATIONS!

NO – Go to 9A.7.4.

9A.7.4 CHECK IF THERE IS SUFFICIENT WATER IN THE CLEAN WATER TANK?

YES – Contact Calnan Service Department.

NO – Fill the tank with clean water (see Manual Section 7 for instructions). Switch on water heater.

Does the water heater work now?

YES – CONGRATULATIONS!

NO – Contact Calnan Service Department.

9A – Diagnostics – Eco+, Eco Hybrid

To contact Calnan Service Department, call (021) 4820260 or email sales@calnan.ie

9A.8 ROOM HEATER NOT WORKING FAN, PLINTH

9A.8.1 ARE THE CABIN POWER ISOLATOR SWITCH AND GENERATOR ON?

YES – Go to 9A.8.2

NO – Turn Cabin Power Isolator switch on.

Then press the green button on generator control panel to start.

Is the heater working now?

YES – CONGRATULATIONS!

NO – Go to 9A.8.2.

9A.8.2 IS THE HEATER ISOLATOR SWITCH ON?



The fan heater isolator switch is found on the wall in the canteen. The plinth heater switch is found underneath the bench seating.

YES – Contact Calnan Service Department.

NO – Switch on.

Is the heater working now?

YES – CONGRATULATIONS!

NO – Contact Calnan Service Department.

9A.9 ROOM HEATER NOT WORKING WEBASTO 12V HVO/DIESEL HEATER

9A.9.1 CHECK THE CONTROL KNOB OR SWITCH. IS THE GREEN LIGHT OFF?

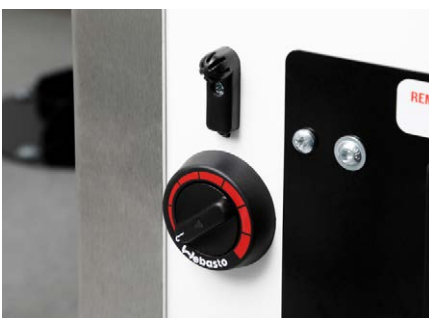

YES – Start the generator to charge the battery. The diesel heater runs off 12V battery power so needs a charged battery to function.

NO – Go to 9A.9.2.

Wait for a while until the battery is charged then try to operate the heater again. Is the heater working now? You will see a solid green light if it is operating correctly.

YES – CONGRATULATIONS! If you have an ECO HYBRID system, call Calnan Service Department to ascertain why your Smart Gauge has not automatically turned the generator on to charge the battery.

9A – Diagnostics – Eco+, Eco Hybrid

NO – Contact Calnans Service Department.

To contact Calnan Service Department, call (021) 4820260 or email sales@calnan.ie

9A.9.2 CHECK THE WEBASTO CONTROL KNOB. IS THE GREEN LIGHT FLASHING?

NO – If green light is on and solid (not flashing) but heater not working, contact Calnan Service Department.

YES – Count the long flashes and consult the Webasto manual to see what fault is indicated.

Follow the steps indicated in the Webasto manual to correct the fault. Is the Heater working now.

YES – CONGRATULATIONS!

NO – Contact Calnan Service Department.

9A.10 ELECTRIC HYDRAULIC SYSTEM NOT WORKING – NO POWER TO RAMS WHEN REMOTE CONTROL IS OPERATED

9A.10.1 CHECK THE CABIN POWER ISOLATOR SWITCH IN THE CANTEEN – IS IT IN ON POSITION?

YES – Go to 9A.10.2

NO – Turn on the Cabin Power Isolator.

Do the electric rams operate now?

YES – CONGRATULATIONS!

NO – Go to 9A.10.2

9A.10.2 CHECK BATTERY VOLTAGE – IS THE VOLTAGE SHOWING AS >12.2V?



To check battery voltage, use the DSE panel on top of the generator. Press ▼ four times until you reach the battery voltage display.

YES – Contact Calnan Service Department.

NO – Go to 9A.10.3

9A.10.3 IS THERE VOLTAGE SHOWING BUT IT IS <12.2V?

NO – If no voltage is shown at all, replace the battery.

YES – If some voltage, run generator to recharge the battery until voltage shows as >12.2V.

Do the electric rams work now?

YES – CONGRATULATIONS! If you have an ECO HYBRID system, call Calnan Service Department to ascertain why your Smart Gauge has not automatically turned the generator on to charge the battery.

NO – Contact Calnan Service Department

9A.11 GENERATOR STOPS RUNNING BUT THEN RESTARTS REDBOX INFINITY GENERATORS ONLY



This is a normal function of your RedBox Infinity generator. Every 50 hours of operation, the generator will stop to perform an automatic oil change cycle which takes 5 minutes. While the oil change is happening a red light will come on on the generator control panel in the canteen.

During the oil change cycle, a valve is automatically opened allowing the oil from the engine sump to drain to the external oil tank. The oil from the engine merges with the oil inside the external tank then the oil is pumped back into the engine sump passing through the oil filter and delivering clean oil back into the engine. After 5 minutes and when the oil in the engine sump is at the correct level the valve is closed and the pump stops.

The generator is now available for use and will restart automatically.

9A.I2 GENERATOR STARTS RUNNING WITH NO USER INTERVENTION

ECO HYBRID ONLY

This is a normal function of your generator with the ECO HYBRID electrical specifications. The ECO HYBRID system is equipped with a Smart Gauge that ensures the battery is automatically recharged when the battery voltage drops below a certain point (C50). The generator will switch on automatically and run for a certain period of time to charge the battery before switching itself off automatically when it reaches a charge of C95.

You can check the battery's charge level at any time by pressing the Status button on the Smart Gauge control panel. In most mobile welfare cabins, this is found in the canteen. In the 24ft, this is found in the office.

9A.I3 GENERATOR STOPS RUNNING AFTER 50 MINUTES USE

If no fault lights are shown when the generator has switched off, this is a normal function of the generator in ECO+ and ECO HYBRID systems. An automatic timed cut-out is programmed into the generator to make sure it switches off if users accidentally leaving it running. Press the green button to restart.

WARRANTIES



10

10.1 MANUFACTURER STANDARD WARRANTY – 12 MONTHS



All manufactured units are covered by a 12 month warranty. The manufacturer undertakes to replace or repair, free of charge, any defect which the company considers to be due to faulty workmanship or material within 12 months of the sale date, except for:

- Defects arising from neglect, misuse or unauthorised modifications. Damage caused by abuse, misuse, dropping or other similar damage caused by or as a result of failure to follow transportation, storage, loading or operating instructions.
- Alterations, additions or repairs carried out by persons other than the manufacturer or their recognised distributors.
- Transportation or shipment costs to and from the manufacturer or their recognised agents, for repair or assessment against a warranty claim, on any mobile welfare unit or component.
- Materials and/or labour costs to renew, repair or replace components due to fair wear and tear.
- Faults arising from the use of non standard or additional parts, or any consequential damage or wear caused by the fitting or use of such parts.



IMPORTANT

Warranty may at the sole discretion of the manufacturer be void if the scheduled service/ inspections are not carried out in accordance with the service manual. It is essential for any warranty to be given consideration that a warranty claim form is submitted.

The manufacturer and/or their recognised agents, directors, employees or insurers will not be held liable for consequential or other damages, losses or expenses in connection with, or by reason of, the inability to use the mobile welfare unit for any purpose.

If additional equipment or any third party work, modifications or alterations are to be carried out on the welfare unit which will involve any welding, drilling or any form of cutting or distortion of materials, full written approval must be obtained from the manufacturer prior to the work being carried out.

10.2 GENERATOR SERVICING & WARRANTY



All Redbox and Redbox Infinity generators carry a warranty of 12 months from date of dispatch or 2000 hours, whichever comes sooner.

During the warranty period, should the generator fail due to faulty design, materials or workmanship we undertake to rectify the fault in line with our standard warranty terms.

Calnan will accept no responsibility whatsoever for equipment that has failed due to:

- Operation with incorrect fuel, lubricating oil.
- Improper repair or use of parts not supplied by Calnan.
- Lack of, or incorrect, maintenance.
- Fair wear and tear, misuse, negligence, accidental damage, improper storage, incorrect starting / warm-up / run-in or shutdown.

No warranty claim will be considered by Calnan unless any defective parts are available for inspection by us, or our nominees, to determine the reason or cause of failure, and Redbox Power is given the option of repair or replacement.

For servicing requirements please refer to the Redbox / Redbox Infinity Generator Operation & Maintenance Manual for full details.

TOWING ADVICE & LEGAL OBLIGATIONS

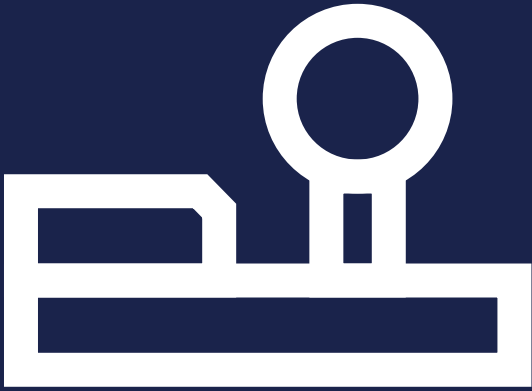

II.1 LEGAL OBLIGATIONS – CABIN & TOWING VEHICLE

II.1.1 TOWING SPEED RESTRICTION

The towing speed limit for this unit is not to exceed 50 mph (80 km/h). The unit is not designed for towing or manoeuvring at higher speeds.

II.1.2 TOWING VEHICLE

The towing vehicle must be suitable for towing the unit. The selection must be made whilst considering the maximum mass (MTPLM) and the towing limit, the Gross Train Weight (GTW) and the load imposed on the rear axle of the towing vehicle.

II.1.3 VIN PLATE

All modern trailer vehicles must carry a manufacturer’s plate giving certain details. From October 2012 this has become part of the European type approval process. The plates must contain information relevant to the loading and towing of the trailer.

The plate is affixed to the front bulkhead of the trailer under the anti-vandal cover.

It contains the Vehicle Identification Number (VIN) which is also marked on the right side of the drawbar.

It also contains the European Type approval reference [3] and details about the mass of the unit.

The maximum mass (MTPLM) of the trailer is shown at position 5 whilst the maximum imposed loading on the coupling is shown at position 6 and the maximum axle load at position 7.

The operator of the trailer should use these weights to determine that the tow vehicle is suitable and that the unit is being used legally.

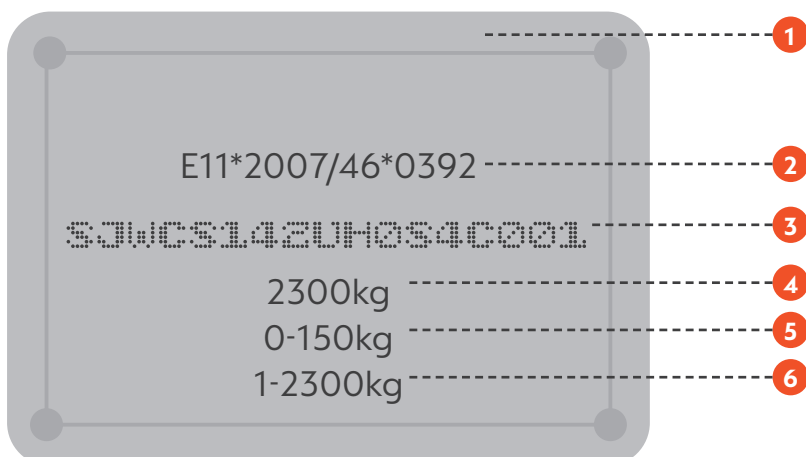

Number	Refers To
1.	VIN Plate
2.	Vehicle Type Approval
3.	Serial Number
4.	Max Weight
5.	Coupling Rated Mass
6.	Axle Rated Mass

11.1.4 TOWING BRACKET

The towing vehicle must be fitted with a good quality towing bracket, preferably in accordance with Directive 94/20/EC and fitted and used in accordance with the manufacturer's instructions.

11.1.5 REGISTRATION PLATE

The cabin must be fitted with a correctly positioned approved 520 × 120 mm number plate in the place provided. The plate must bear the same registration mark as that of the towing vehicle.

11.1.6 TOWING MIRRORS

Before using a trailer on the road the operator must ensure that the visibility through the rear view mirrors is correct.

The welfare unit may be wider than the towing vehicle. This means the standard mirrors fitted to the towing vehicle will be inadequate for compliance with the relevant legal requirements.

Extension mirrors must be fitted and adjusted to ensure the yellow shaded area in the diagram is visible in the mirrors for both sides of the vehicle.

Mirrors fitted must be "e" marked and correctly fitted to give adequate visibility.

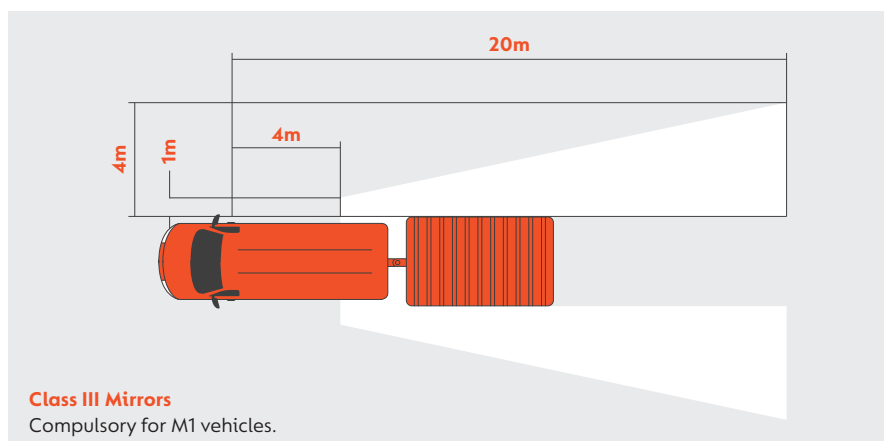
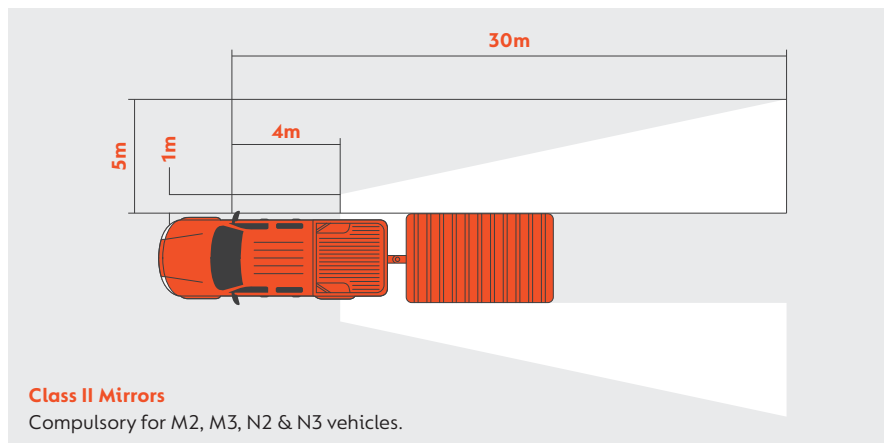

11.1.7 ROAD LIGHTING

It is an offence to tow a trailer or permit a trailer to be towed on the road without adequate and properly functioning lighting.

The trailer is delivered with fully compliant road lighting.

The trailer is connected to the towing vehicle using a standard 13 pin plug and socket.

It is the responsibility of the operator to ensure that all lights are operating and undamaged before using the unit on the public roads.

This class of trailer requires the following lights to be fitted and working.

Number	Type	Colour	Quantity
1.	Number Plate Lamp	White	1 or 2
2.	Mini LED Combination Lamp consisting of:		
2a.	Stop Lamp	Red	2
2b.	Rear Position Lamp	Red	2
2c.	Direction Indication	Amber	2
3.	Mini LED Combination Lamp consisting of:		
3a.	Fog Lamp	Red	1
3b.	Reversing Lamp	White	1
4.	Triangular Reflector	Red	2
5.	End Outline Marker Lamp	Red and White	2
6.	Side Marker Lamp	Amber	4
7.	Front Position (Side) Lamp	White	2

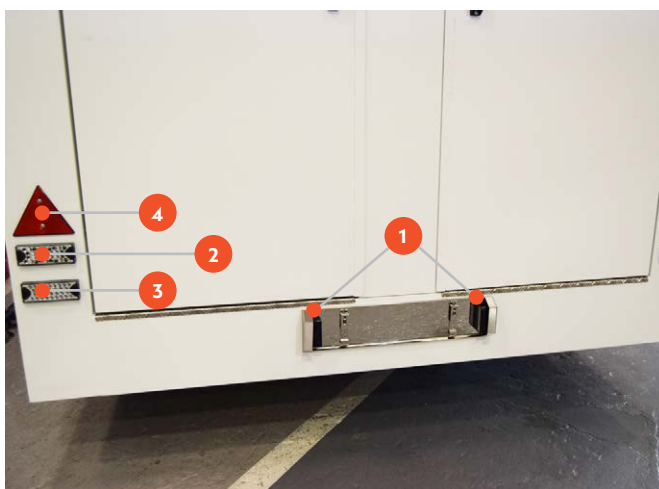

11.2 LEGAL OBLIGATIONS

– TOWING VEHICLE DRIVER

People are often ignorant of the towing laws and legal requirements especially when only towing with a standard car licence (Category B).

For photo card licences issued in the UK and other EU countries, the vehicle categories you are entitled to drive are shown on Line 9 on the front. A more detailed breakdown and the applicable dates are shown on the rear.



If you have a B1 or higher category driving licence, you are legally permitted to tow any size of trailer.

If you have a Category B and BE licence only (awarded on passing the standard UK driving test), check the date your licence was issued and use the following information and flow diagrams to determine what trailers you are able to tow and to match the tow vehicle to the trailer.

MTPLM	Maximum Technically Permissible Laden Mass (of the trailer).
MRO	Mass in Running Order (unladen or ex-works mass).
MAM	Maximum Authorised Mass (Max weight of Towing vehicle).
GTW	Gross Train Weight (Trailer & Towing vehicle weights combined).
MTM	Maximum Towable Mass (the weight a towing vehicle is allowed to tow as indicated by its manufacturer).

CAT B LICENCE HELD BEFORE 1ST JAN 1997

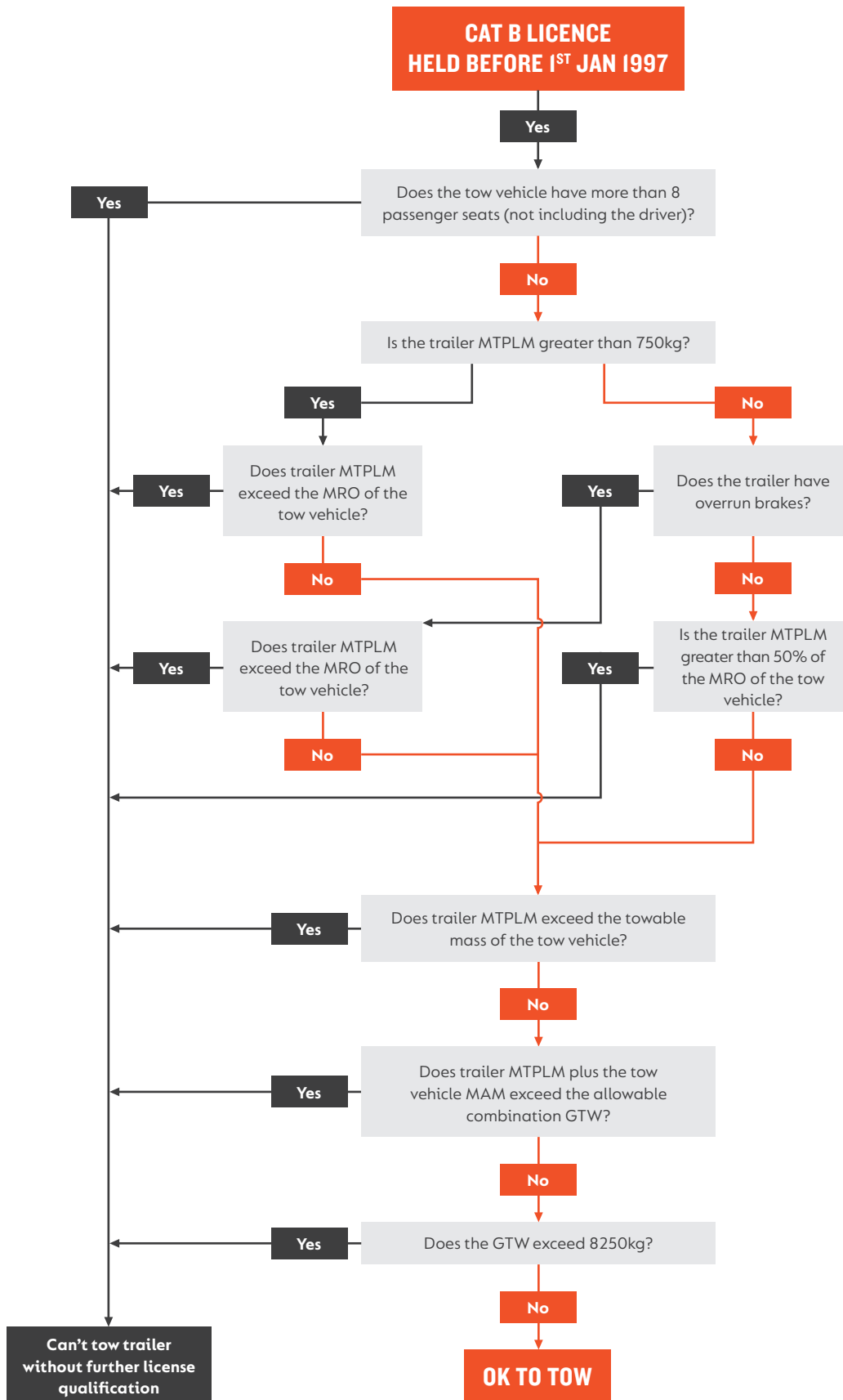

CAT B LICENCE HELD AFTER 1ST JANUARY 1997 BUT BEFORE 19TH JANUARY 2013

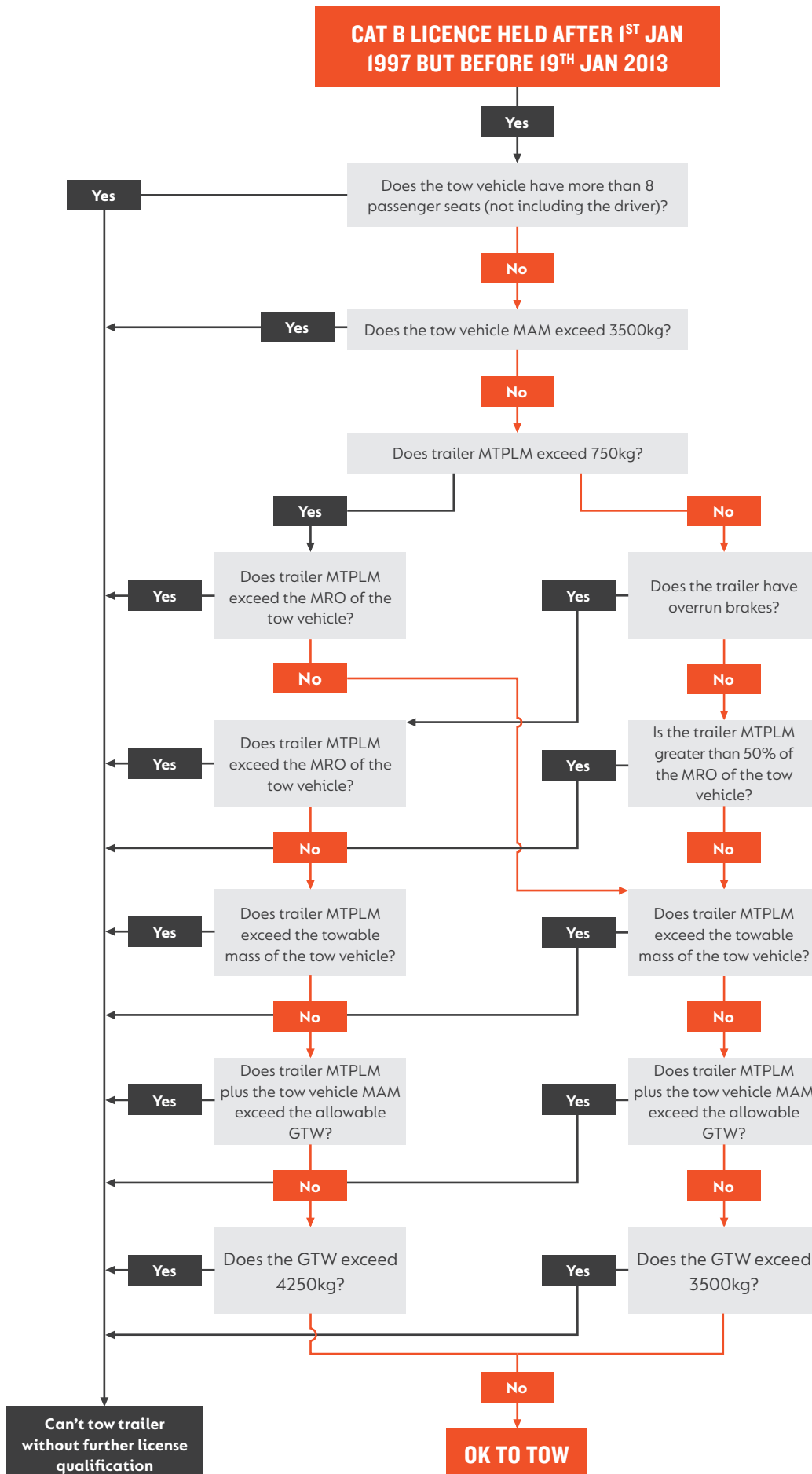

CAT B LICENCE HELD AFTER 19TH JANUARY 2013

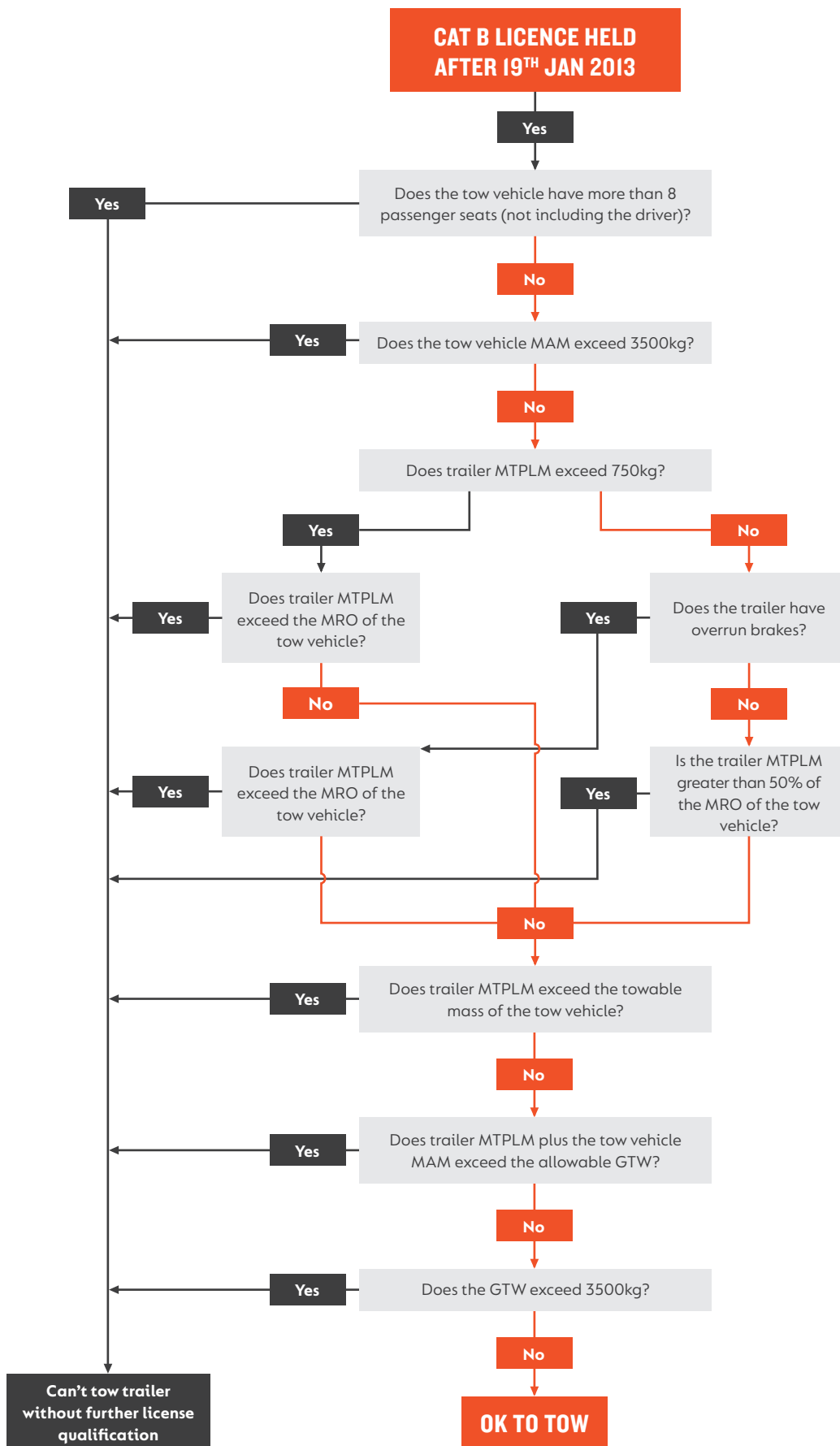

11.3 DRIVING ADVICE

Dependant on the model, Our welfare units are equipped with either a single or tandem axle. For inexperienced users this may make manoeuvring difficult, especially where space is limited. Don't take chances, if in doubt and where visibility is limited always get someone to guide or assist you.

The addition of a trailer lengthens the effective wheelbase of the towing vehicle, it may also impair the rearward visibility and make cornering and reversing more challenging.

We strongly recommend that anyone towing one of their welfare units undertakes professional training and accreditation.

11.3.1 TURNING LEFT

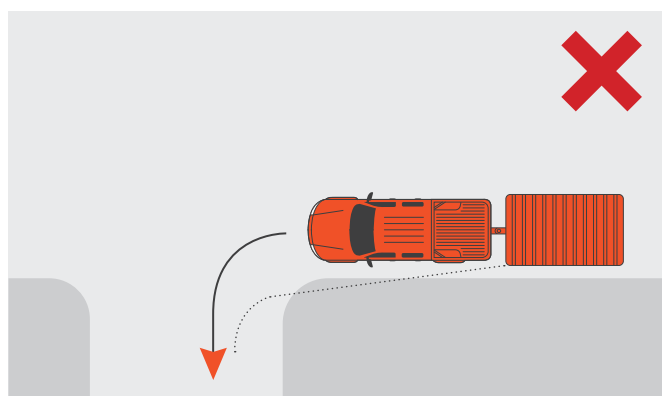

When turning left it is important to remember that the trailer does not take the same route around the corner as the towing vehicle. For example if the towing vehicle is positioned too close to the kerb or the driver does not allow sufficient additional distance when turning, the trailer will cut across the corner. This will inevitably damage the trailer and possibly the towing vehicle.

More seriously it could cause injury to a pedestrian or cyclist, and cause damage to the highway infrastructure.

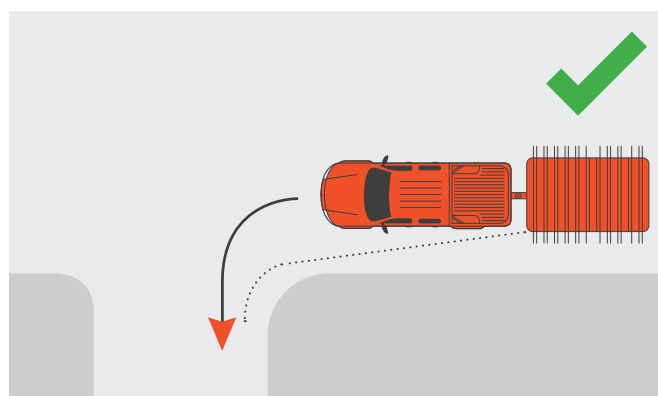

Allow plenty of time to manoeuvre and adjust your road position so as to be further from the kerb, without conflicting with other traffic.

Never overtake slower moving traffic before making a turn. Check your mirrors, especially the left side before making a left turn and ensure there are no cyclists or pedestrians that may be affected by the manoeuvre.

Check the trailer position, and look into the junction to check for any conflicting traffic. Make your turn slightly later than if you were driving without a trailer, this widens the turning circle, allowing the trailer to clear the kerb.

11.3.2 REVERSING THE UNIT

Reversing a trailer requires additional skills, and observation.

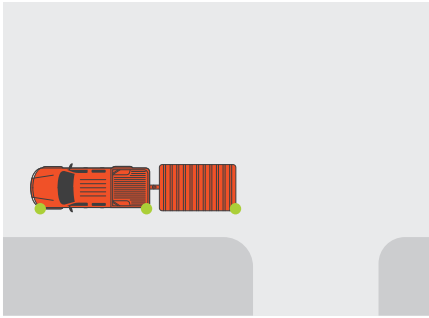

1) Position the towing vehicle parallel to the kerb and if conditions allow, approximately 1m to 1.5m from it.

Allow at least one trailer length from the rear of the trailer to the junction if possible.

Check behind the trailer for any obstructions, then when the road is clear start the manoeuvre by reversing slowly straight back.

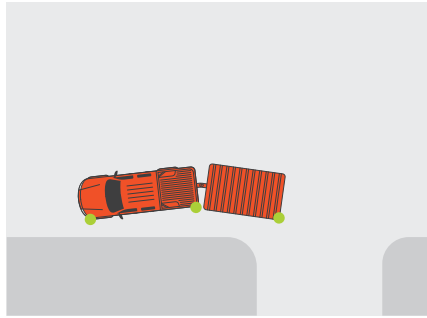

2) Whilst reversing slowly turn the steering wheel opposite to the direction of the turn. Check your mirrors both sides for conflicting traffic and to watch the position of the trailer. As the rear of the towing vehicle turns away from the kerb, watch the rear of the trailer and it will start to turn into the junction.

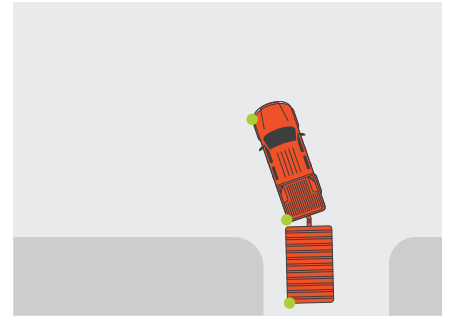

3) As the trailer starts to turn, turn the steering wheel into the normal lock for the curve. Follow the trailer into the junction.

If the trailer starts to turn in too tightly, turn the steering wheel further to the left to correct it.

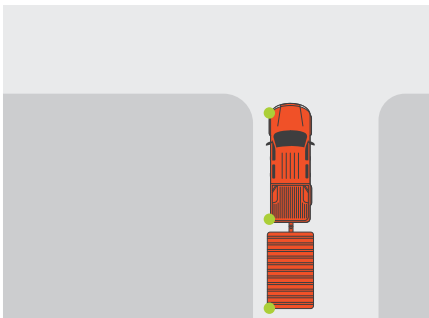

4) When fully into the junction, turn the steering to the left to straighten up the trailer.

You may need to steer further to the left than is normal to compensate for the trailer, so ensure you use your mirrors to look for conflicting traffic and obstructions.

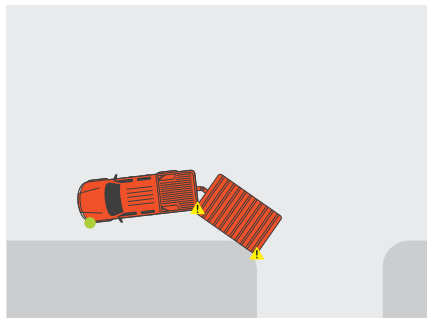

CAUTION

If you lose control of the trailer whilst reversing, the most likely result will be to jack-knife. This is where the trailer turning circle decreases quickly and the towing vehicle cannot steer to correct it. In this condition the only method of correction is to stop, then pull forward to straighten up the trailer, then start the reversing procedure again.

Jack-knifing the trailer can cause instability, and inevitably causes damage to trailer and the towing vehicle.

OTHER INFORMATION



12

12.1 SAFETY DECALS



Advises the operator to ensure all loose articles are removed from the cabin before towing.

The cabin is not a payload vehicle. No materials, tools, clothing or equipment are to be carried in the vehicle whilst being towed on the highway.



Warns the operator that 240V equipment is fitted and in use in the cabin.

No unqualified or unauthorised personnel are allowed to work on or maintain this equipment.

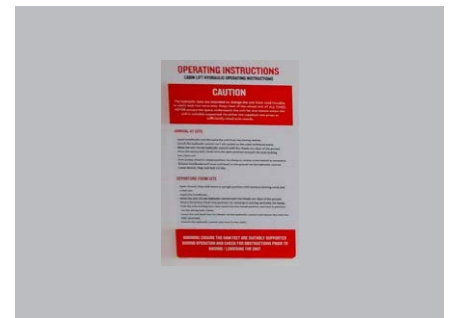

General operating instructions for arriving on site, towing and departing.

 Do we have all the decals?

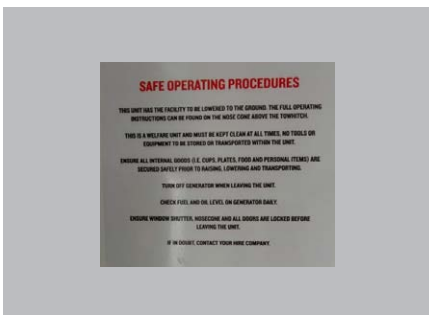

General safety instructions. Roles and responsibilities for hirers and operators.



Affixed to washing facilities to advise the operator that water in these units may not be fit for drinking.

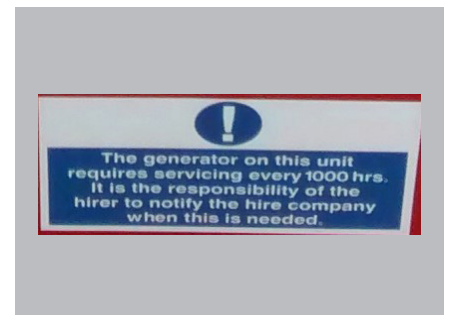

Generator service interval decal.



Reminds the operator to check the tyre pressures and condition prior to use.



Warns the operator to ensure the hydraulic cylinders are properly supported before they are lowered.

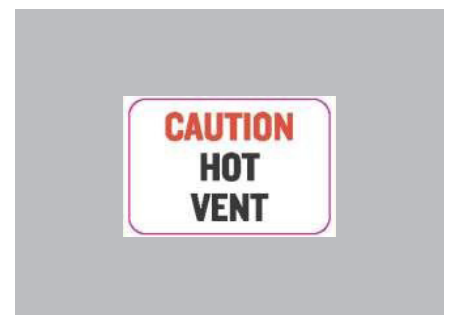

Warns the operator of the proximity of hot surfaces or exhaust outlets associated with the generator and heating equipment.



Reminds the operator that after a generator alarm event the generator will not restart unless reset.



Reminds the operator to ensure the cabin is electrically isolated when not attended (when fitted).

LEGAL REQUIREMENTS – MOBILE WELFARE



Calnan mobile welfare units are fully compliant with all current legislation and directives regarding welfare facilities.

13

13.1 ONSITE WELFARE PROVISION – CONSTRUCTION (DESIGN AND MANAGEMENT) REGULATIONS 2015

The welfare of all personnel employed on construction sites and in similar environments is the responsibility of employers, contractors and clients and is set out in the Construction (Design and Management) Regulations 2015 (UK only, other EU countries and non-EU countries regulations may vary).

The use of welfare units will allow employers to comply with some or all of the stipulations below. The nature and scale of facilities required will depend on the size, location and type of project. For everyone, on site facilities must include:

TOILETS

Toilets should be suitable and sufficient, ventilated, lit and kept in a clean and orderly condition. Washing facilities must be provided so that workers can use them immediately after using the toilet or urinal, even if they are provided elsewhere. Our toilets all comply with current mobile toilet regulations **BS EN 16194 2012 – Mobile non-sewer-connected toilet cabins**.

WASHING FACILITIES

General washing facilities must be suitable and sufficient, kept clean and orderly and with basins or sinks large enough for people to wash their face, hands and forearms.

The facilities should include:

- Clean hot and cold, or warm, running water.
- Soap or other suitable means of cleaning.
- Towels or other suitable means of drying.

DRINKING WATER

Drinking water must be provided or made available at readily accessible and suitable places. Cups are required unless the supply is in a jet from which people can drink easily.

CHANGING ROOMS AND LOCKERS

Changing rooms are needed where workers have to wear special clothing for the purposes of their work and cannot be expected to change elsewhere. The rooms must be provided with seating, means of drying and keeping clothing and personal effects secure.

FACILITIES FOR REST AND CONSUMING REFRESHMENTS

Rest rooms or rest areas are required equipped with tables and seating (with backs) sufficient for the number of persons likely to use them at any one time. There should be arrangements for meals to be prepared and eaten, plus means for boiling water. In cold weather, heating should be provided.

13.2 ROADWORTHINESS – VCA TYPE APPROVAL UNDER DIRECTIVE 2007/46/EC



All mobile welfare units have been granted **VCA Type Approval under Directive 2007/46/EC** and are certified roadworthy.

13.3 ELECTRIC INSTALLATIONS – BS7671 IET WIRING REGULATIONS 18TH EDITION



All electrical installations are independently checked and conform with the latest legal recommendations **BS7671 IET Wiring Regulations 18th Edition**.

In addition, we certify all our cabins with Gold Standard Electrics, our own independent-testing scheme.

Calnan Group

Brook Lodge East, Glanmire,
Co. Cork, Ireland T45HX99

sales@calnan.ie

Cork: (021) 4820260, Meath: (046) 9247175

www.calnan.ie

